

# VENUS X1PRO

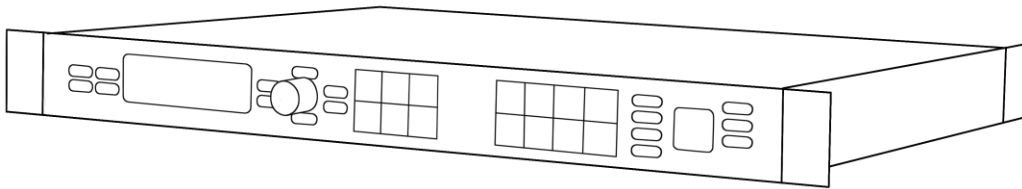

## USER MANUAL

# RGBlink

Article No: RGB-RD-UM-X1PRO E001  
Revision No: V1.2

# CONTENTS

CONTENTS .....	1
<i>Declarations</i> .....	3
FCC/Warranty .....	3
Operators Safety Summary .....	4
Installation Safety Summary.....	4
<i>Chapter 1 Your Product</i> .....	6
1.1 In the Box.....	6
1.2 Product Overview .....	7
1.2.1 Back Panel .....	8
1.2.2 Front Panel .....	10
1.2.3 Dimension .....	12
<i>Chapter 2 Installing Your Product</i> .....	13
2.1 Plugging in Signals .....	13
2.2 Plugging in Main Power.....	13
2.3 Turning on Your Product .....	13
<i>Chapter 3 Using Your Product</i> .....	15
3.1 Using the MENU Button .....	15
3.2 Understanding the MENU Structure .....	16
3.3 Using the Menu .....	17
3.3.1 Understanding the Display .....	17
3.3.2 Understanding the Main Menu .....	18
3.3.3 Input Menu.....	19
3.3.4 Output Menu.....	20
3.3.5 Picture Menu.....	21
3.3.6 Split Menu .....	22
3.3.7 Transition Menu .....	22
3.3.8 Scale Menu .....	23
3.3.9 Save Setup Menu.....	23
3.3.10 System Menu.....	24
3.3.11 Language Menu.....	25
3.3.12 Factory Reset Menu.....	25
3.4 Default Mode .....	26
3.4.1 Single Image Switching.....	26
3.4.2 PIP Setting .....	26
3.4.3 Scale the Image .....	27
3.4.4 Zoom the Image .....	28
3.4.5 Image Quality Setting.....	28
3.5 4K Mode .....	30
3.6 Split Mode .....	31
3.6.1 FOUR PORT OUTPUT .....	31
3.6.2 BACKUP MODE .....	34
3.7 Independent Output Mode .....	36

3.8 Cascade Mode .....	37
3.9 Set the Output Resolution .....	38
3.9.1 Select the Output Resolution .....	38
3.9.2 Custom the Output Resolution .....	39
3.10 User Define Black Key .....	41
3.11 Transition Setting .....	43
3.12 Screen Size Setting .....	44
3.13 Using Black Out .....	45
3.14 Saving Views .....	46
3.15 Recall Saved Settings .....	47
<i>Chapter 4 Ordering Codes</i> .....	48
4.1 Product .....	48
4.2 Options .....	48
4.2.1 Input Options .....	48
4.2.2 Output Options .....	49
4.3 Sender Cards .....	49
<i>Chapter 5 Support</i> .....	50
5.1 Questions and Troubleshooting .....	50
5.1.1 The Preview Output Problems and Issues .....	50
5.2 Contact Us .....	52
<i>Chapter 6 Appendix</i> .....	53
6.1 Specification .....	53
6.2 Software Upgrade .....	60
6.3 Installing Options .....	63
6.3.1 Installing Input Module .....	63
6.3.2 Installing Output Module .....	68
6.3.3 Installing WIFI Module .....	71
6.4 Connect WIFI .....	73
6.5 Terms & Definitions .....	75
6.6 Revision History .....	79

---

**Thank you for choosing our product!**

**This User Manual is designed to show you how to use this video processor quickly and make use of all the features. Please read all directions and instructions carefully before using this product.**

## *Declarations*

### FCC/Warranty

#### **Federal Communications Commission (FCC) Statement**

This equipment has been tested and found to comply with the limits for a class A digital device, pursuant to Part 15 of the FCC rules. These limits are designed to provide reasonable protection against harmful interference when the equipment is operated in a commercial environment. This equipment generates, uses, and can radiate radio frequency energy and, if not installed and used in accordance with the instruction manual, may cause harmful interference to radio communications. Operation of this equipment in a residential area may cause harmful interference, in which case the user will be responsible for correcting any interference.

#### **Guarantee and Compensation**

RGBlink provides a guarantee relating to perfect manufacturing as part of the legally stipulated terms of guarantee. On receipt, the purchaser must immediately inspect all delivered goods for damage incurred during transport, as well as for material and manufacturing faults. RGBlink must be informed immediately in writing of any complaints.

The period of guarantee begins on the date of transfer of risks, in the case of special systems and software on the date of commissioning, at latest 30 days after the transfer of risks. In the event of justified notice of complaint, RGBlink can repair the fault or provide a replacement at its own discretion within an appropriate period. If this measure proves to be impossible or unsuccessful, the purchaser can demand a reduction in the purchase price or cancellation of the contract. All other claims, in particular those relating to compensation for direct or indirect damage, and also damage attributed to the operation of software as well as to other service provided by RGBlink, being a component of the system or independent service, will be deemed invalid provided the damage is not proven to be attributed to the absence of properties guaranteed in writing or due to the intent or gross negligence or part of RGBlink. If the purchaser or a third party carries out modifications or repairs on goods delivered by RGBlink, or if the goods are handled incorrectly, in particular if the systems are commissioned operated incorrectly or if, after the transfer of risks, the goods are subject to influences not agreed upon in the contract, all guarantee claims of the purchaser will be rendered invalid. Not included in the guarantee coverage are system failures which are attributed to programs or special electronic circuitry provided by the purchaser, e.g. interfaces. Normal wear as well as normal maintenance are not subject to the guarantee provided by RGBlink either.

The environmental conditions as well as the servicing and maintenance regulations specified in this manual must be complied with by the customer.

# Operators Safety Summary

The general safety information in this summary is for operating personnel.

## Do Not Remove Covers or Panels

There are no user-serviceable parts within the unit. Removal of the top cover will expose dangerous voltages. To avoid personal injury, do not remove the top cover. Do not operate the unit without the cover installed.

## Power Source

This product is intended to operate from a power source that will not apply more than 230 volts rms between the supply conductors or between both supply conductor and ground. A protective ground connection by way of grounding conductor in the power cord is essential for safe operation.

## Grounding the Product

This product is grounded through the grounding conductor of the power cord. To avoid electrical shock, plug the power cord into a properly wired receptacle before connecting to the product input or output terminals. A protective-ground connection by way of the grounding conductor in the power cord is essential for safe operation.

## Use the Proper Power Cord

Use only the power cord and connector specified for your product. Use only a power cord that is in good condition. Refer cord and connector changes to qualified service personnel.

## Use the Proper Fuse

To avoid fire hazard, use only the fuse having identical type, voltage rating, and current rating characteristics. Refer fuse replacement to qualified service personnel.

## Do Not Operate in Explosive Atmospheres

To avoid explosion, do not operate this product in an explosive atmosphere.

# Installation Safety Summary

## Safety Precautions

For all VENUS X1PRO processor installation procedures, please observe the following important safety and handling rules to avoid damage to yourself and the equipment.

To protect users from electric shock, ensure that the chassis connects to earth via the ground wire provided in the AC power Cord.

The AC Socket-outlet should be installed near the equipment and be easily accessible.

## Unpacking and Inspection

Before opening VENUS X1PRO processor shipping box, inspect it for damage. If you find any damage, notify the shipping carrier immediately for all claims adjustments. As you open the box, compare its contents against the packing slip. If you find any shortages, contact your sales representative.

Once you have removed all the components from their packaging and checked that all the listed components are present, visually inspect the system to ensure there was no damage during shipping. If there is damage, notify the shipping carrier immediately for all claims adjustments.

## **Site Preparation**

The environment in which you install your VENUS X1PRO should be clean, properly lit, free from static, and have adequate power, ventilation, and space for all components.

# Chapter 1 Your Product

---

## 1.1 In the Box

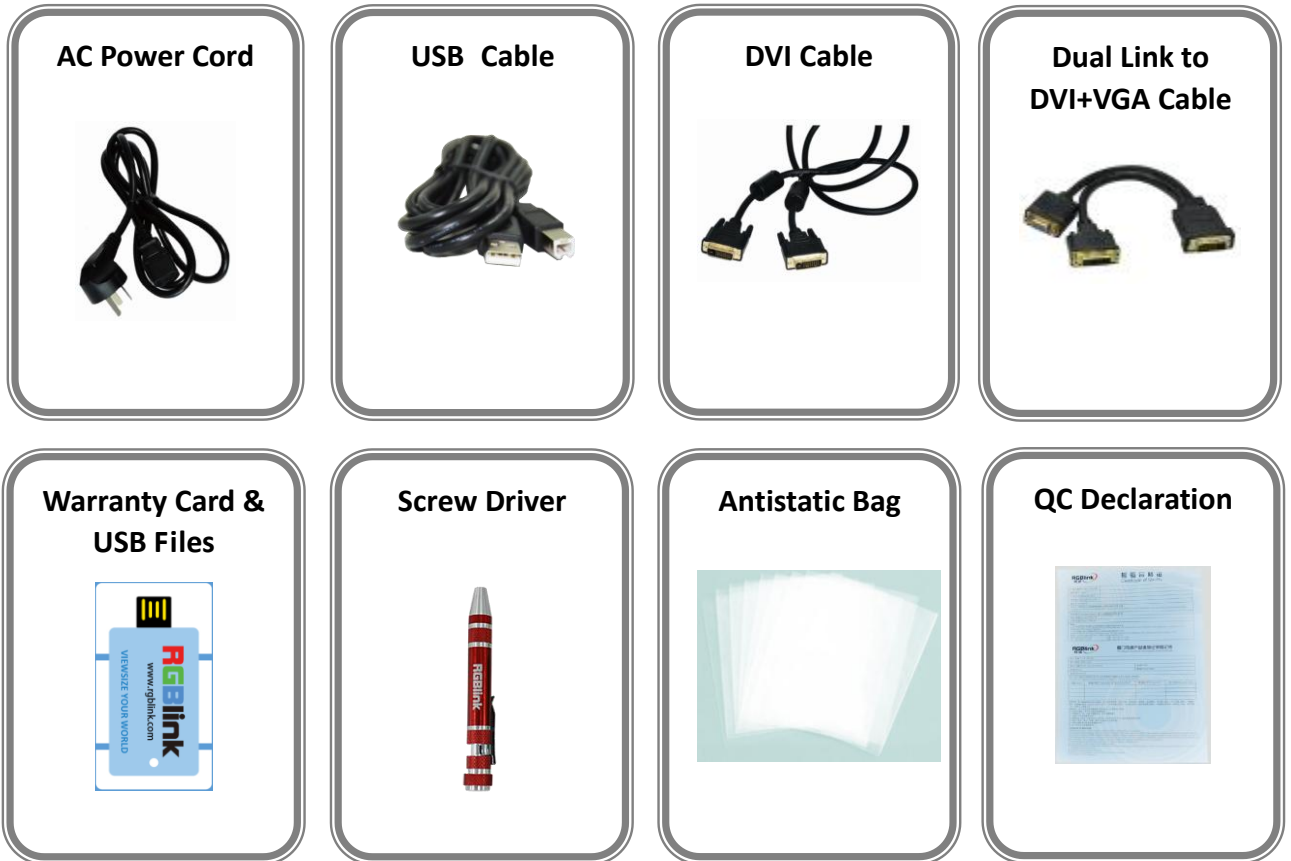

**Note:**

AC Power Cable supplied as standard according to destination market.

USB is contained on the Warranty/Registration Card. Please keep.

## 1.2 Product Overview

Simply professional 4K scaling and switching.

4K switching has never been more practical and straight forward. The modular VENUS X1 platform allows the addition of a range of signal options over and above the standard inputs. Standard inputs include 4K signals on Dual Link DVI, HDMI and DisplayPort. Output to DisplayPort as 4K or scale and split across dual 2K DVI outputs. For those needing 4K distribution and splicing on four DVI, simply add the additional output module. The output module expands VENUS X1PRO to four 2K DVI outputs and adds a further DisplayPort output.

Alternately, VENUS X1PRO with the output module can become a 4K presentation switcher with the additional DVI outputs (and DisplayPort) becoming a full preview.

All the power and flexibility familiar with RGBlink X series.



## 1.2.1 Back Panel

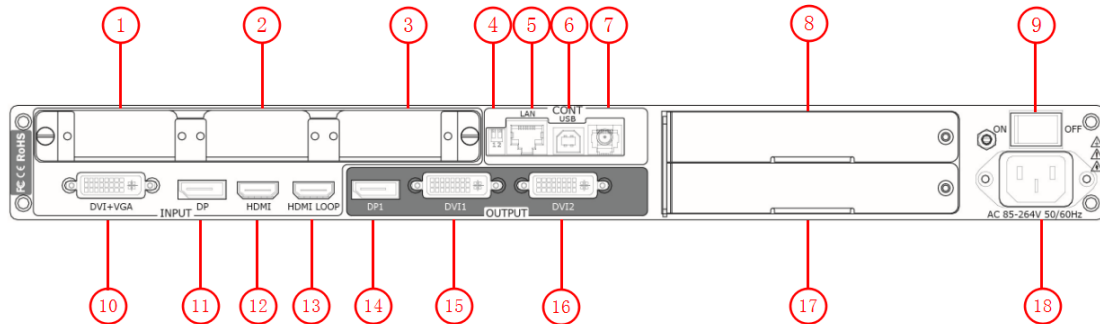

### Input Connectors

10	<p><b><u>DVI-I – DVI</u></b> Standard DVI signals can input. Additionally this DVI port supports VGA with the use of a DVI to VGA adapter. The DVI port supports up to HDMI 1.3 if the port format is set to HDMI.</p>
11	<p><b><u>DP</u></b> Standard DisplayPort signals can input.</p>
12	<p><b><u>HDMI-A – HDMI</u></b> Standard Genlock signals can input.</p>

### Output Connectors

13	<p><b><u>HDMI-A – HDMI LOOP</u></b> Connect to the HDMI input of the next VENUS X1PRO or the device with HDMI input.</p>
14	<p><b><u>DP</u></b> Connect to the device which has DP interface.</p>
15.16	<p><b><u>DVI-I – DVI</u></b> Connect to the monitor or LED display which has DVI interface. (This connector does not support hotplug).</p>

### Control Connectors

4	<p><b><u>DIP Switch</u></b> If the two DIP switches are upwards, the device is in normal work, and if they are downwards, the device is in upgrade state. OLED module light is off when the device is in upgrade state. Some of the button lights turn on, and the device will not work.</p>
5	<p><b><u>RJ45 – Ethernet</u></b> Connect to Ethernet work for remote control by windows software.</p>
6	<p><b><u>USB-B – USB</u></b> Connect to Ethernet work for remote control by Windows software and for product firmware upgrades.</p>

7	<p><b><u>WIFI</u></b> Connect to Ethernet work for remote control by WIFI.</p>
---	--

### Power Connection

9	<p><b><u>Power Switch</u></b> Illuminated power switch.</p>
18	<p><b><u>IEC – Power Input</u></b> Main power input AC 85-264V Max 65W.</p>

### Option Slots

1.2.3	<p><b><u>Input Option Slots</u></b> Range of inputs are available for user fitting. Refer to Product <a href="#">Input Options</a>.</p>
8.17	<p><b><u>Sender Card/Output Option Slots</u></b> Either a Sender Card or Output option can be installed in this slot. Support sender Card types including Linsn, Nova and Colorlight (sold separately) Refer to Product <a href="#">Sender Cards</a>. A range of output options are available for user fitting. Refer to Product <a href="#">Output Options</a>.</p>

## 1.2.2 Front Panel

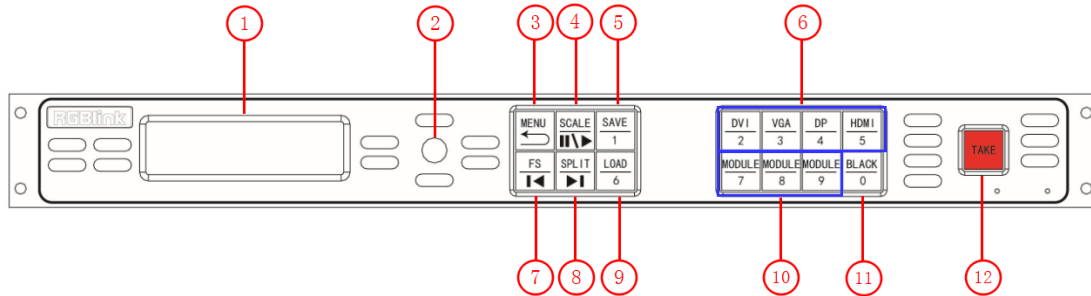

### Display

1	<p><b><u>OLED Display</u></b></p> <p>Displays current status of the product, and for feature selections provides interactive choices in conjunction with buttons on the front panel.</p>
---	--

### Multi-Function Buttons

2	<p><b><u>Rotary Button</u></b></p> <p>This button used for menu selections and confirmation. The button is both rotary (turn to left and right), and push-button (confirm selection)</p>
---	--

### Illuminated Buttons

3	<p><b><u>MENU Button</u></b></p> <p>This button used for menu selections – refer to <a href="#">Understanding the MENU Structure</a>. Push the button again will return to the last level menu or exit the menu. Push the button two times to enter the effect switch function menu. Push the button for 3 seconds will lock the front panel, and push the button for 5 seconds to unlock. Push the <b>MENU</b> and <b>TAKE</b> button for 3 seconds will switch the language.</p>
4	<p><b><u>SCALE Button</u></b></p> <p>This button used for size and position adjusting. When input USB signal, it reused the stop and play button, push the button to stop or play the USB video file.</p>
5	<p><b><u>SAVE Button</u></b></p> <p>Save all current settings with the VENUS X1PRO to 1 of the 36 available slots. For details, please refer to <a href="#">Saving Views</a>. Additionally this button is used for direct numeric entry for numbers 1.</p>
6	<p><b><u>Dedicated Signal Buttons</u></b></p> <p>For each of inputs on the back panel a dedicated backlit buttons are provided. When lit, the signal is selected for use, when red light is flashing, signal is in preview or the signal is not available.</p>

	Additionally, each button is numbered and can be used as direct number entry when values such as resolution and size.
7	<p><b><u>FS Button</u></b></p> <p>Screen parameters setting button. Push the button, its LED light turns on, user can choose full size or screen size, and set the size and position of the screen.</p> <p>When input USB signal, it reused the move previous button, push the button to play the previous USB video file.</p>
8	<p><b><u>SPLIT Button</u></b></p> <p>Split function button.</p> <p>When connect USB signal, it reused the move next button, push the button to play the next USB video file.</p>
9	<p><b><u>LOAD Button</u></b></p> <p>Restores/Loads all current settings with the VENUS X1PRO from 1 of the 36 available slots.</p> <p>For details, please refer to <a href="#">Recall Saved Settings</a>.</p> <p>Additionally this button is used for direct numeric entry for numbers 6.</p>
10	<p><b><u>Optional Signal Buttons</u></b></p> <p>If optional input module is fitted, then these two buttons operate as per Dedicated Signal Buttons above.</p> <p>Additionally these buttons are used for direct numeric entry for numbers 7 / 8 / 9.</p>
11	<p><b><u>BLACK Button</u></b></p> <p>Black button, push the button, its LED light turns on, the output will be switched to black, push the button again, its LED light is off, and output the video image.</p> <p>For details, please refer to <a href="#">Using Black out</a>.</p> <p>Additionally this button is used for direct numeric entry for numbers 0.</p>
12	<p><b><u>TAKE Button</u></b></p> <p>This button used for seamless effect switching.</p>

## 1.2.3 Dimension

Following is the dimension of VENUS X1PRO for your reference:

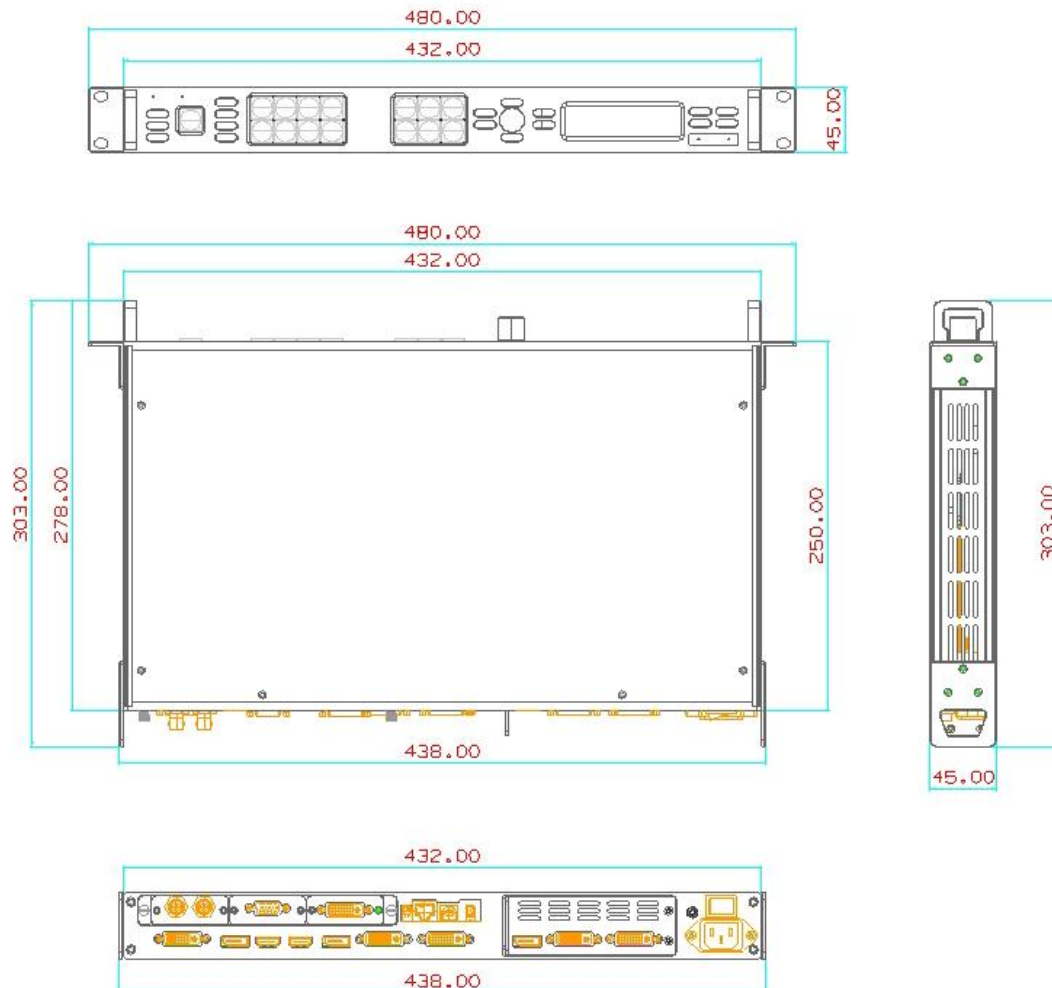

# Chapter 2 Installing Your Product

---

## 2.1 Plugging in Signals

Connect signals to the product (ensure all devices are powered off first). Tighten connector screws/locks where provided.



For connector protection and for additional cable support this product is fitted with protection frames on either side of the device. For cable support use cable ties to attached to the protection frames to avoid stress on signal connectors.



## 2.2 Plugging in Main Power

Connect IEC cable to device and plug into wall socket. Turn on power at wall socket.

## 2.3 Turning on Your Product

Turn the power switch on the rear of the product to the ON position.

OLED display will show as below, completing initialization before loading last settings and input/output configuration.

On delivery, DP will be the default input signal at 1920x1080x60, and the output format is defaulted to 1920x1080x60.

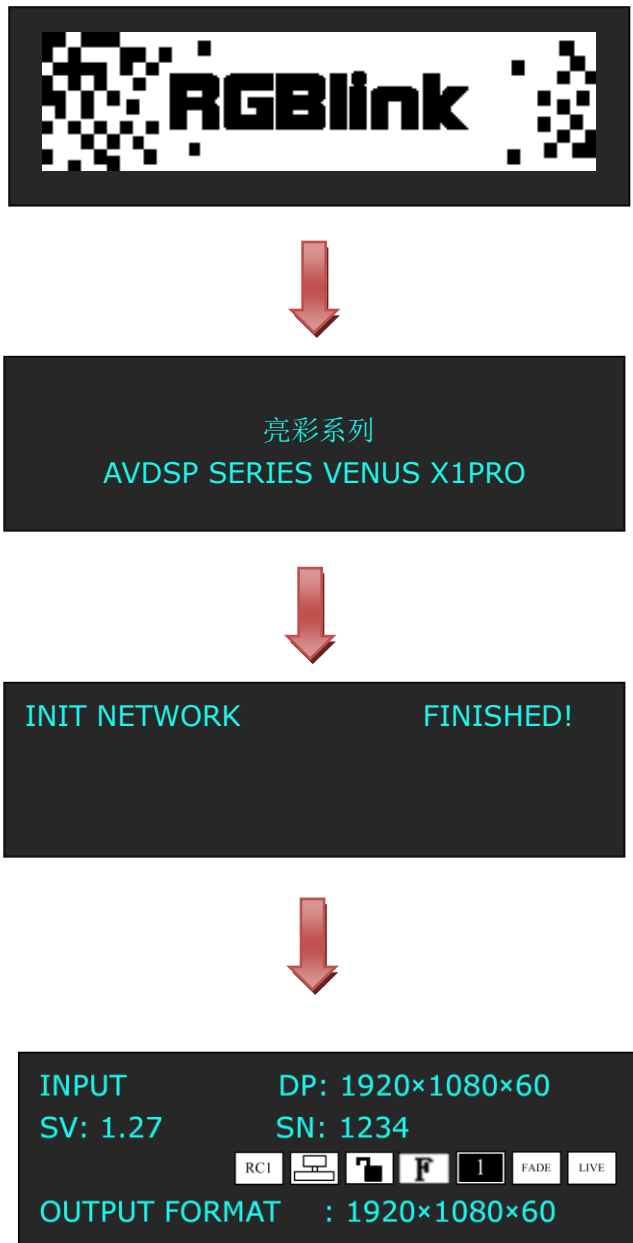

# Chapter 3 Using Your Product

---

## 3.1 Using the MENU Button

Push the [MENU] button to enter the menu display.

Turn the rotary knob to navigate to the menu item required. The → symbol shows the current item. Push the knob to select and enter into the menu item.

As shown in the figure below:

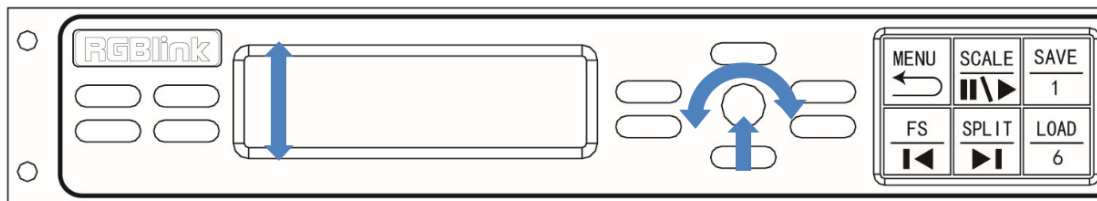



## 3.2 Understanding the MENU Structure

The MENU structure is shown in the figure below:

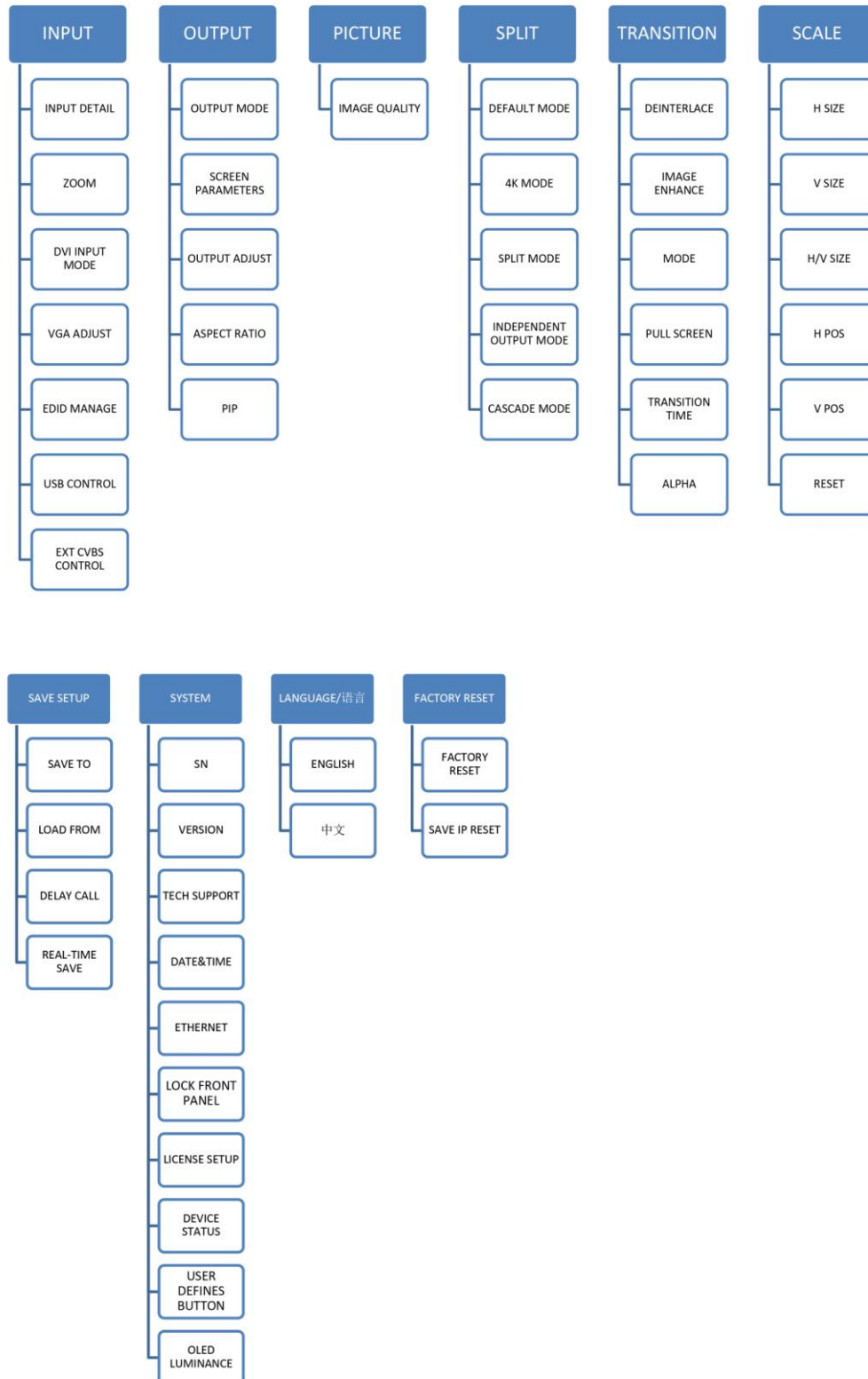

## 3.3 Using the Menu

Use the menu system for convenient and intuitive operation. VENUS X1PRO OLED display shows the menu items. The OLED display will show the default state when the menu is not in use, or the operation has timed out. Using the MENU button and rotary knob in the front panel, the OLED display will show the corresponding menus according to user selections.

### 3.3.1 Understanding the Display

Turn the power switch to the ON position, the OLED display will show the start-up interface and show the default menu after completing initialization as below:

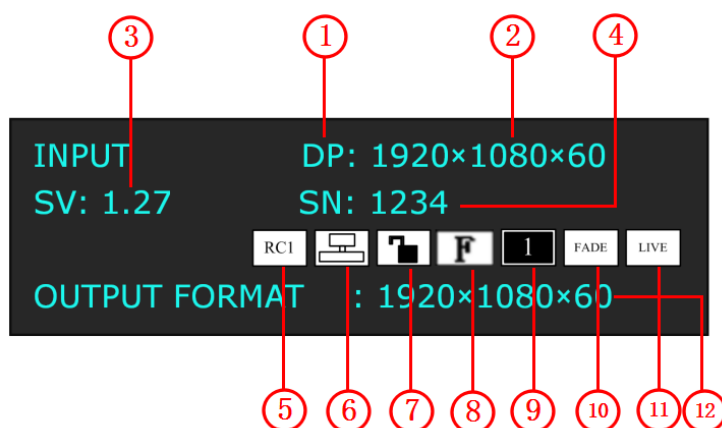

Introduce for the above information:

1	<p><b><u>Input Signal</u></b></p> <p>Shows the current <b>Input</b> signal that is selected. The related dedicated signal button will be lit red.</p>
2	<p><b><u>Input Resolution</u></b></p> <p>Show the current input resolution from the selected <b>Input</b> source. To configure input resolutions, use the EDID Management features. A wide range of input resolutions are supported depending the input – refer to <a href="#">Specification</a>.</p> <p>If a # symbol is show after the resolution, then a custom resolution is being used.</p>
3	<p><b><u>Software version</u></b></p> <p>Shows the software version of the product.</p> <p>When not displayed here, the serial number can be found via the <a href="#">TECH SUPPORT</a> menu.</p>
4	<p><b><u>Serial Number</u></b></p> <p>Shows the serial of the product.</p> <p>When not displayed here, the serial number can be found via the <a href="#">TECH SUPPORT</a> menu.</p>
5	<p><b><u>Recall</u></b></p> <p>Show the current recall position.</p>

6	<b><u>Ethernet</u></b> Displays whether Ethernet connection is active or inactive. Ethernet settings are available in the <a href="#">Ethernet</a> menu.
7	<b><u>Lock</u></b> Indicates if the front panel is locked.
8	<b><u>Full</u></b> Indicates whether the screen size is full size or screen size.
9	<b><u>1</u></b> Indicates the current is single image, image settings are available in the PIP menu.
10	<b><u>Fade</u></b> Indicates whether transitions are CUT or FADE. Configure from the Transition menu.
11	<b><u>Live</u></b> Indicates whether output video Live or whether FREEZE is active.
12	<b><u>Output Resolution</u></b> Show the current output resolution. To configure output resolutions, use the OUTPUT menu. A wide range of resolutions are supported – refer to <a href="#">Specification</a> . If a # symbol is show after the resolution, then a custom resolution is being used.

### 3.3.2 Understanding the Main Menu

Push the MENU button in the default state and turn the rotary knob, the OLED display will show the main menus as below:

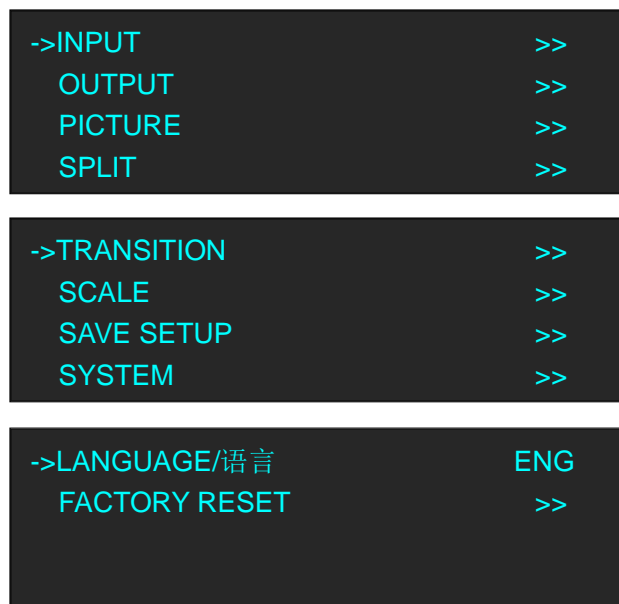

There are 10 menu items in the main menu, and display in 3 pages. Turn the rotary knob, and select any menu above, push the rotary knob to confirm, the OLED display will show the submenu. If push the MENU button, the OLED display will return to the last level menu.

### 3.3.3 Input Menu

```
->INPUT DETAIL      >>
    ZOOM             >>
    DVI INPUT MODE   >>
    VGA ADJUST       >>
```

```
->EDID MANAGE      >>
    USB CONTROL     >>
    EXT CVBS CONTROL >>
```

INPUT DETAIL	Display the input source and input format.
ZOOM	<b><u>V UP</u></b> Image to up zoom.
	<b><u>V DOWN</u></b> Image to down zoom.
	<b><u>V UP/DOWN</u></b> Image to up and down zoom.
	<b><u>H LEFT</u></b> Image to left zoom.
	<b><u>H RIGHT</u></b> Image to right zoom.
	<b><u>H LEFT/RIGHT</u></b> Image to left and right zoom.
	<b><u>CENTER</u></b> Image from center to the edges zoom.
	<b><u>RESET</u></b> If image quality distorts by improper operation, it can be recover by reset.
DVI INPUT MODE	Select single link or dual link.
VGA ADJUST	H POS, V POS, CLOCK and PHASE setting, or select auto adjust.
EDID MANAGE	<b><u>DESTINATION PORT</u></b> Select the destination port, DVI, HDMI or DP.
	<b><u>EDID SOURCE</u></b> Select the EDID source.
USB CONTROL	<b><u>USB PORT</u></b> Select PORT A or PORT B.
	<b><u>PLAY MODE</u></b> Select video or photo, default video.
	<b><u>PLAY FILE</u></b> Select the file to play.
	<b><u>PLAY ORDER</u></b>

	Select REPEAT ALL, RANDOM, ORDER, SINGLE CYCLE, SINGLE TRACK or PLAY LIST.
	<b><u>PLAY STATE</u></b> Select play or pause.
EXT CVBS CONTROL	<b><u>CVBS PORT</u></b> Select PORT A or PORT B.
	<b><u>INPUT FORMAT</u></b> Display the input format of CVBS.

### 3.3.4 Output Menu

->OUTPUT MODE	>>
SCREEN PARAMETERS	>>
OUTPUT ADJUST	>>
ASPECT RATIO	DEFAULT
->PIP	>>

OUTPUT MODE	<b><u>DEFAULT MODE</u></b> Select standard resolution or custom the resolution.
	<b><u>4K MODE</u></b> Select standard resolution or custom the resolution.
	<b><u>SPLIT MODE</u></b> Select four port output or backup mode.
	<b><u>INDEPENDENT MODE</u></b> Select DVI&DVI2 split or DVI&DVI2 split.
	<b><u>CASCADE MODE</u></b> Select four port split or backup split.
SCREEN PARAMETERS	<b><u>H SIZE</u></b> Width setting.
	<b><u>V SIZE</u></b> Height setting.
	<b><u>H POS</u></b> Horizontal phase setting.
	<b><u>V POS</u></b> Vertical phase setting.
	<b><u>MODE</u></b> Select SCREEN SIZE or FULL SIZE.
	<b><u>SCREEN FOLLOW SCALE</u></b>

	Enable or disable screen follow scale function.
	<b><u>RESET</u></b> If image quality distorts by improper operation, it can be recover by reset.
OUTPUT ADJUST	<b><u>DVI1</u></b> Select DVI mode, bit depth and data range, and set DE. If image quality distorts by improper operation, it can be recover by reset.
	<b><u>DVI2</u></b> Select DVI mode, bit depth and data range, and set DE. If image quality distorts by improper operation, it can be recover by reset.
	<b><u>DVI3</u></b> Select DVI mode, bit depth and data range, and set DE. If image quality distorts by improper operation, it can be recover by reset.
	<b><u>DVI4</u></b> Select DVI mode, bit depth and data range, and set DE. If image quality distorts by improper operation, it can be recover by reset.
ASPECT RATIO	Select 4:3, 16:9 or default.
PIP	<b><u>PIP</u></b> Enable or disable the PIP function.
	<b><u>LAYOUT</u></b> Select PIP L+T, PIP R+T, PIP L+B, PIP R+B, PIP CENTER, PBP L+R or PBP T+B.
	<b><u>SELECT</u></b> Select IMAGE A or IMAGE B.
	<b><u>SWAP WINDOW</u></b> Enable or disable swap window function.
	<b><u>ALPHA</u></b> The adjustment range is 0~16.

### 3.3.5 Picture Menu

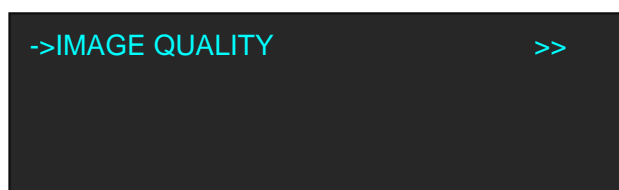
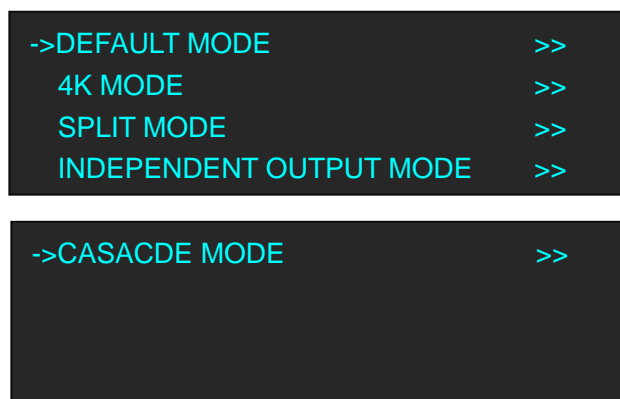

IMAGE QUALITY	<b><u>BRIGHTNESS</u></b> Brightness adjust, the adjustment range is 0~100.
	<b><u>CONTRAST</u></b> Contrast adjust, the adjustment range is 0~100.
	<b><u>SATURATION</u></b> Saturation adjust, the adjustment range is 0~100.
	<b><u>SHARPNESS</u></b> Sharpness adjust, the adjustment range is 0~100.

	<b><u>COLOR RED</u></b> Color red adjust, the adjustment range is 0~100.
	<b><u>COLOR GRN</u></b> Color green adjust, the adjustment range is 0~100.
	<b><u>COLOR BLUE</u></b> Color blue adjust, the adjustment range is 0~100.
	<b><u>GAMMA</u></b> Gamma setting, can select LINEAR, sRGB, -1.2, 1.2, -1.4, 1.4, -1.6 or 1.6.
	<b><u>RESET</u></b> If image quality distorts by improper operation, it can be recover by reset.

### 3.3.6 Split Menu



DEFAULT MODE	Select standard resolution or custom the resolution. For details, please refer to <a href="#">Default Mode</a> .
4K MODE	Select standard resolution or custom the resolution. For details, please refer to <a href="#">4K Mode</a> .
SPLIT MODE	Select four port output or backup mode. For details, please refer to <a href="#">Split Mode</a> .
INDEPENDENT OUTPUT MODE	Select DVI&DVI2 split or DVI&DVI2 split. For details, please refer to <a href="#">Independent Mode</a> .
CASCADE MODE	Select four port split or backup split. For details, please refer to <a href="#">Cascade Mode</a> .

### 3.3.7 Transition Menu

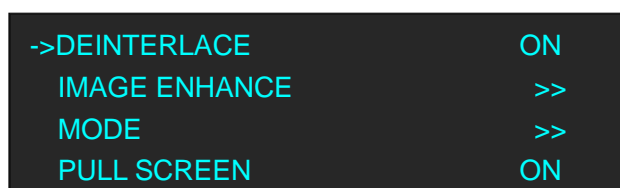

```

->TRANSITION TIME    >>
  ALPHA              >>

```

DEINTERLACE	Enable or disable deinterlace function.
IMAGE ENHANCE	Enable or disable image enhance function.
MODE	Transition mode selection, including Dissolve, Cut, Wipe Square In, Wipe Square Out, Wipe Top Left In, Wipe Top Left Out, Wipe Top Right In, Wipe Top Right Out, Wipe Bottom Left In, Wipe Bottom Left Out, Wipe Bottom Right In, Wipe Bottom Right Out, Wipe Left In, Wipe Left Out, Wipe Right In, Wipe Right Out, Wipe Top In, Wipe Top Out, Wipe Bottom In and Wipe Bottom Out.
PULL SCREEN	Enable or disable pull screen function.
TRANSITION TIME	Transition time setting, the adjustment range is from 0.1 to 3S.
ALPHA	Alpha setting, the adjustment range is from 0 to 16S.

### 3.3.8 Scale Menu

```

->H SIZE    >>
  V SIZE    >>
  H/V SIZE  >>
  H POS     >>

```

```

->V POS    >>
  RESET

```

H SIZE	Width setting.
V SIZE	Height setting.
H/V SIZE	Width and height equal proportion scale setting.
H POS	Horizontal phase setting.
V POS	Vertical phase setting.
RESET	If image quality distorts by improper operation, it can be recover by reset.

### 3.3.9 Save Setup Menu



```

->SAVE TO          >>
   LOAD FROM      >>
   DELAY CALL     >>
   REAL-TIME SAVE >>

```

SAVE TO	Save all current settings with the VENUS X1PRO to 1 of the 36 available slots.
LOAD FROM	Restores/Loads all current settings with the VENUS X1PRO from 1 of the 36 available slots
DELAY CALL	Delay output time setting.
REAL-TIME SAVE	Enable or disable the real-time save function.

### 3.3.10 System Menu

```

->SN              >>
   VERSION        >>
   TECH SUPPORT   >>
   DATE&TIME     >>

```

```

->ETHERNET       >>
   LOCK FRONT PANEL >>
   LICENSE SETUP  >>
   DEVICE STATUS  >>

```

```

->USER DEFINES BUTTON >>
   OLED LUMINANCE    >>

```

SN	Display the serial number of the device.
VERSION	Display the software and hardware version of the device.
TECH SUPPORT	Display sales, after-sale service, email, website and telephone.
DATE&TIME	Display the date, time, work time, total time and boot times. User can also change the date and time.
ETHERNET	Enable or disable the network function. If select "ON", user can set the IP address, subnet mask and gateway.
LOCK FRONT PANEL	Lock front panel function. If the key is locked, the equipment will remind: "Buttons are locked! Press MENU key and hold 5s to release!"
LICENSE SETUP	The device will not work if excess the prescribed time, there are no signal output, it needs to input password and modify the using time to continue to work.
DEVICE STATUS	Display the video status, EXT status and PRE status.

USER DEFINES BUTTON	Default black function, can define this button as FREEZE, TEST PATTERN and BRIGHT.
OLED LUMINANCE	OLED luminance adjust, the adjustment range is 1~15.

### 3.3.11 Language Menu

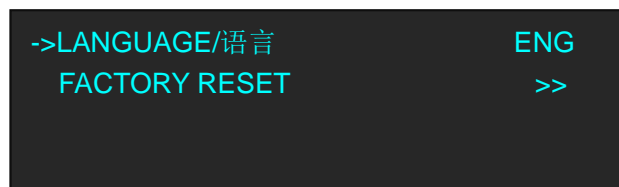

Language	Select Chinese or English.
----------	----------------------------

### 3.3.12 Factory Reset Menu

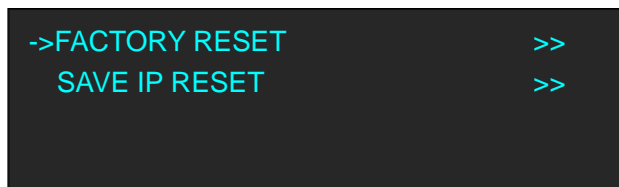

FACTORY RESET	Select "YES" or "NO". Select "YES" to restore default settings.
SAVE IP RESET	Select "YES" or "NO". Select "YES" to restore default settings, but keep the IP.

## 3.4 Default Mode

In default mode, both output channels output the same signal and resolution.

PIP is available for use.

This is the default mode following a reset.

### 3.4.1 Single Image Switching

Default DP for the current input source, if need switch other signal, for example, DVI, push the DVI button.

DP button light will be off after pushing the DVI button, and DVI button light will be on if the DVI signal is effective and stable. If the DVI signal is invalid or no input, DVI button light will flash.

same with above, switch the signals among HDMI and input option signal.

### 3.4.2 PIP Setting

#### Enable the PIP function

VENUS X1PRO supports seamless switching for single image and double images.

1. Push the [MENU] button, and enter to menu items, turn the rotary knob, select <OUTPUT>.



2. Push the knob to confirm, turn the rotary knob again, and select <PIP>.



3. Push the knob to confirm, and enter to the menu items as follows:

->PIP	ON
LAYOUT	PIP L+T
SELECT	IMAGE A
SWAP WINDOW	OFF

  

->ALPHA	0
---------	---

4. Turn the rotary knob again, select <PIP>, and set "ON".

**Layout :**

Select any one from PIP L+T, PIP R+T, PIP L+B, PIP R+B, PIP CENTER, PBP L+R and PBP T+B, take 3 layouts for example, shown as follows:

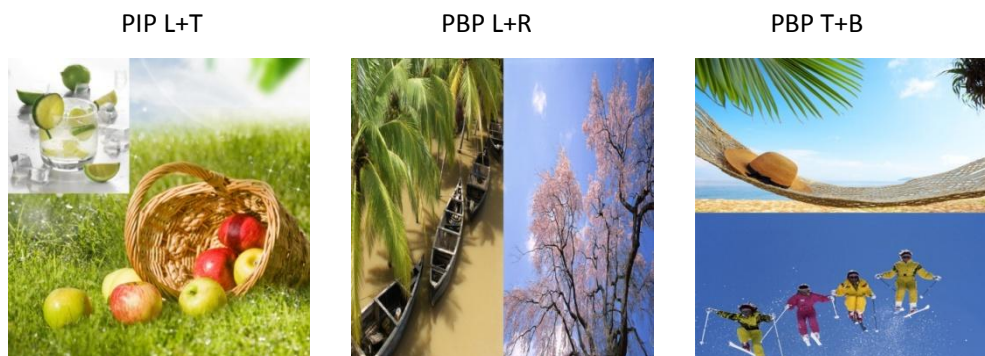

**Select:**

Select image A or image B. For example, select image B, the settings will be available for image B.

**Swap Window:**

Enable or disable the swap window function.

**Alpha:**

Image transparency setting, the adjustment range is 0 to 16.

### 3.4.3 Scale the Image

Push the [SCALE] button, and enter to the scale menus as follows.

->H SIZE	1920
V SIZE	1080
H/V SIZE	0
H POS	0

->V POS	0
RESET	

User can adjust the following items by the rotary knob or number buttons.

**H SIZE:** Width setting.

**V SIZE:** Height setting.

**H/V SIZE:** Width and height equal proportion scale setting.

**H POS:** Horizontal phase setting.

**V POS:** Vertical phase setting.

**RESET:** If image quality distorts by improper operation, it can be recover by reset.

### 3.4.4 Zoom the Image

The image can be zoom in horizontal or vertical separately, to meet the special effects required.

Push the [MENU] button to go into the menu items, turn the rotary knob and select <INPUT>, push the knob to confirm. Turn the rotary knob again, select <ZOOM>, and enter to the zoom menus as follows:

->V UP	0
V DOWN	0
V UP/DOWN	0
H LEFT	0

->H RIGHT	0
H LEFT/RIGHT	0
CENTER	0
RESET	

**V UP:** Zoom in vertical and the image will be zoom in to the top direction from its bottom.

**V DOWN:** Zoom in vertical and the image will be zoom in to the down direction from its top.

**V UP/DOWN:** Zoom in vertical but in both top and down direction from its middle.

**H LEFT:** Zoom in horizontal and the image will be zoom in to the left direction from its right.

**H RIGHT:** Zoom in horizontal and the image will be zoom in to the right direction from its left.

**H LEFT/RIGHT:** Zoom in horizontal but in both left and right direction from its middle.

**CENTER:** Zoom in 4 corner direction from center.

**RESET:** If image quality distorts by improper operation, it can be recover by reset.

### 3.4.5 Image Quality Setting

1. Push the [MENU] button, and enter to the menu items. Turn the rotary knob, and select <PICTURE>, push the knob to confirm, and enter to the menu items as follows:



->IMAGE QUALITY >>

2. Push the knob to confirm, and enter to the menu items as follows.



->BRIGHTNESS 50  
CONTRAST 50  
SATURATION 50  
SHARPNESS 50



->COLOR RED 50  
COLOR GREEN 50  
COLOR BLUE 50  
GAMMA LINEAR



->RESET

3. Adjust the brightness, contrast, saturation, sharpness, color red, color green, color blue and gamma according to actual need. If image quality distorts by improper operation, it can be recover by reset.

**Note**

If user define the [BLACK] button as "BRIGHTNESS", push the [BLACK/BRIGHTNESS] button will enter to the above menu items.

## 3.5 4K Mode

VENUS X1PRO equipped with 4K module, and the output resolution can up to 4K×1K. Same with default mode, it supports single image switching, PIP setting, scale the image, zoom the image and image quality setting.

Additionally, 4K mode supports split and preview.

## 3.6 Split Mode

Push the [SPLIT] button, and enter to the output mode menus. Turn the rotary knob, and select <SPLIT MODE>, which including <FOUR PORT OUTPUT> and <BACKUP MODE>.

```
->FOUR PORT OUTPUT    >>
    BACKUP MODE        >>
```

### 3.6.1 FOUR PORT OUTPUT

Default <FOUR PORT OUTPUT> option. Push the knob to confirm, and enter to the menu items as follows:

```
->DEMO                >>
    SYNC                >>
```

<DEMO> and <SYNC> with the same operation steps, the different is for the end device. DEMO is used when connect the device to the display, while SYNC is used when connect the device to the LED screen. Select any one, for example, select <DEMO>, enter to the menu items as follows:

```
->CROSS                >>
    H 1/4              >>
    V 1/2              >>
    H 1/2              >>
```

### CROSS

Turn the rotary knob, and select <CROSS>, push the knob to confirm, and enter to the menu items as follows:

```
->H TOTAL              3840
    V TOTAL            2160
    WIDTH 1            1920
    WIDTH 2            1920
```

```
->WIDTH 3              1920
    WIDTH 4            1920
    HEIGHT 1           1080
    HEIGHT 2           1080
```





->RESET

Set H total, V total, width and height of each screen according to actual need.

For example, set H total as 3840, V total as 2160, Width 1 as 1920 and Height 1 as 1080, then

Width 3 will be 1920 ( H total <3840> - Width 1 <1920> = Width 3 <1920> ).

Height 2 will be 1080 ( V total <2160> - Height 1 <1080> = Height 2 <1080> ).

As shown in the figure below:

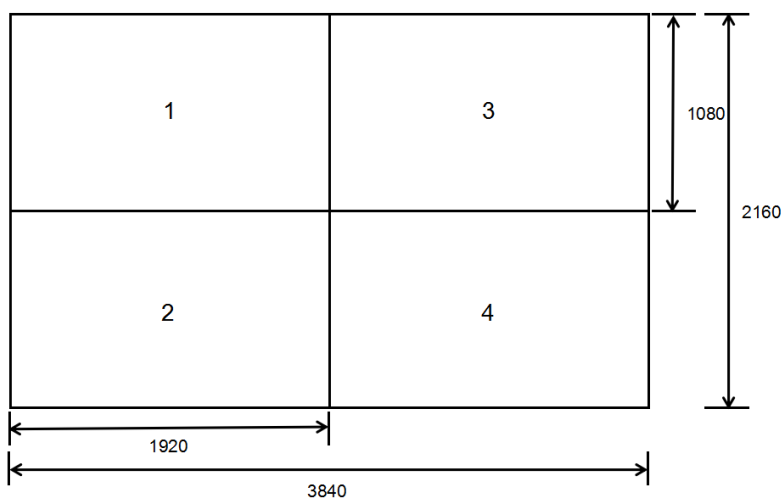

## H 1/4

Turn the rotary knob, and select <H 1/4>, push the knob to confirm, and enter to the menu items as follows:



->H TOTAL	7680
V TOTAL	1080
WIDTH 1	1920
WIDTH 2	1920



->WIDTH 3	1920
WIDTH 4	1920
HEIGHT 1	1080
RESET	

Set H total, V total, width and height of each screen according to actual need.

For example, set H total as 7680, V total as 1080, Width 1, 2, 3 and 4 as 1920 ( H total <7680> = Width 1 <1920> + Width 2 <1920> + Width 3 <1920> + Width 4 <1920> ).

Height 1 is 1080, same with V total.

As shown in the figure below:

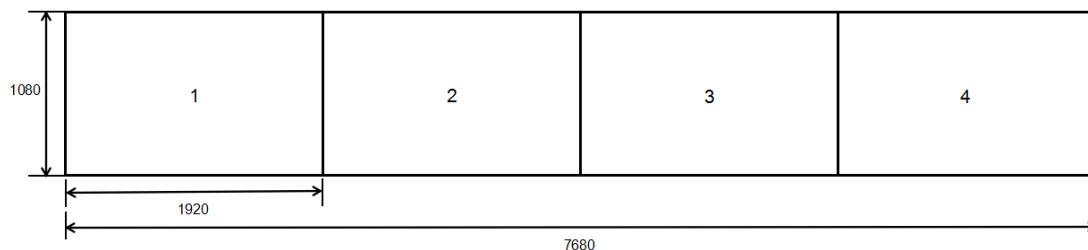

### V 1/2

Turn the rotary knob, and select <V 1/2>, push the knob to confirm, and enter to the menu items as follows:

->H TOTAL	1920
V TOTAL	2160
WIDTH 1	1920
HEIGHT 1	1080
->HEIGHT 2	1080
RESET	

Set H total, V total, width and height of each screen according to actual need.

For example, set H total as 1920, V total as 2160, Width 1 is 1920, same with H total.

Set Height 1 as 1080 and Height 2 will be 1080, ( V total <2160> - Height 1 <1080> = Height 2 <1080> ).

As shown in the figure below:

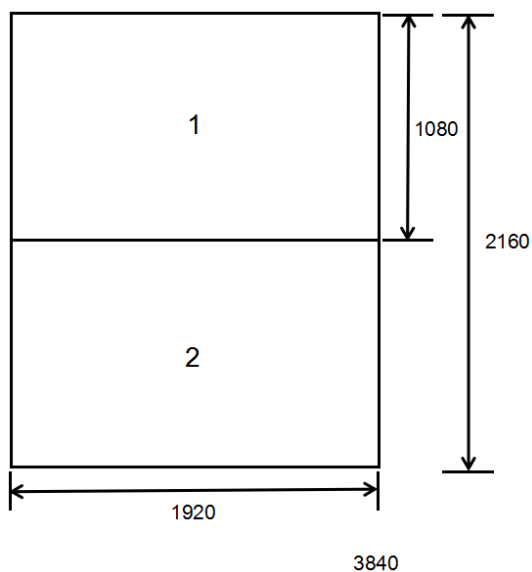

## H 1/2

Turn the rotary knob, and select <H 1/2>, push the knob to confirm, and enter to the menu items as follows:

->H TOTAL	3840
V TOTAL	1080
WIDTH 1	1920
WIDTH 2	1920

->HEIGHT 1	1080
RESET	

Set H total, V total, width and height of each screen according to actual need.

For example, set H total as 3840, V total as 1080, Height 1 is 1080, same with V total.

Set Width 1 as 1920 and Width 2 will be 1920, ( H total <3840> - Width 1 <1920> = Width 2 <1920> ).

As shown in the figure below:

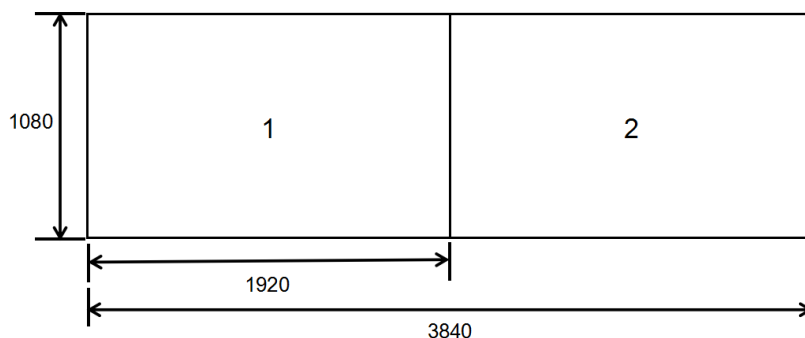

## 3.6.2 BACKUP MODE

Turn the rotary knob, and select <BACKUP MODE>, push the knob to confirm, and enter to the menu items as follows:

FOUR PORT OUTPUT	>>
->BACKUP MODE	>>



->H TOTAL	1920
V TOTAL	1080
H POS	0
V POS	0

->H SIZE	1920
V SIZE	1080
RESET	

Backup mode is same with two port output, settings are as follows:

H TOTAL: LED screen Horizontal total size.

V TOTAL: LED screen Vertical total size.

H POS: This device display image Horizontal size.

V POS: This device display image Vertical size.

H SIZE: This device display image Width setting.

V SIZE: This device display image Height setting.

RESET: If image quality distorts by improper operation, it can be recover by reset.

**Note**

The split mode can not support seamless switching,  
recommend to add a seamless switcher in front-end.

## 3.7 Independent Output Mode

Each of the two output channels can have individually have resolution and scale set.

There is no PIP in this mode.

**Note**

VENUS X1PRO V1.2 can not support this function.

## 3.8 Cascade Mode

Allows splitting a input signal across both output channels, and also provides setting where the source is to be split across more than one device.

There is no PIP in this mode.

**Note**

VENUS X1PRO V1.2 can not support this function.

## 3.9 Set the Output Resolution

### 3.9.1 Select the Output Resolution

1. Push the [MENU] button, and enter to the menu items, turn the rotary knob, and select <OUTPUT>:



2. Push the knob to confirm, and enter to the menu items as follows:

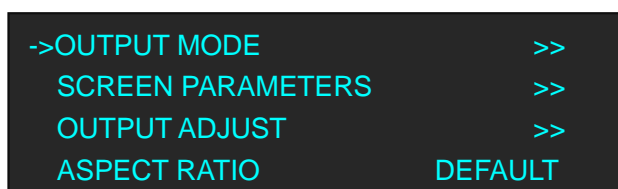

3. Default <OUTPUT MODE> option, push the knob to confirm, and enter to the menu items as follows:

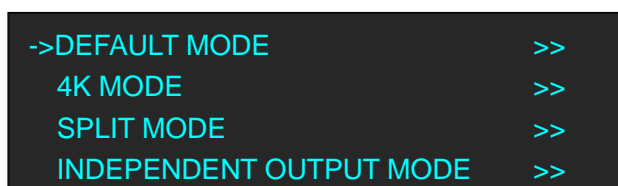

4. Select <DEFAULT MODE> or <4K MODE> according to actual need, push the knob to confirm, and enter to the menu items as follows:

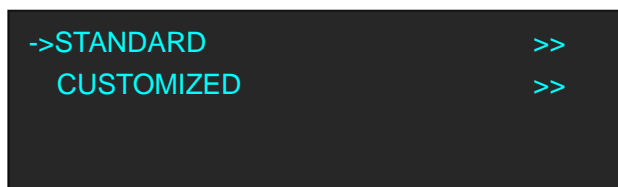

5. Default <STANDARD> option, push the knob to confirm. Turn the rotary knob, and select the output format according to actual need.

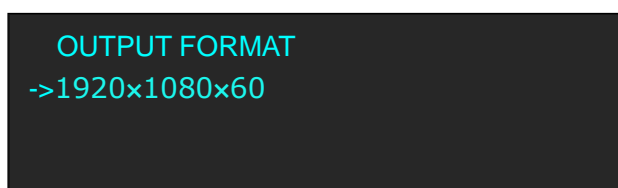

### 3.9.2 Custom the Output Resolution

1. Push the [MENU] button, and enter to the menu items, turn the rotary knob, and select <OUTPUT>:



2. Push the knob to confirm, and enter to the menu items as follows:

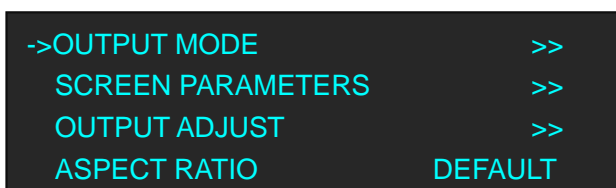

3. Default <OUTPUT MODE> option, push the knob to confirm, and enter to the menu items as follows:

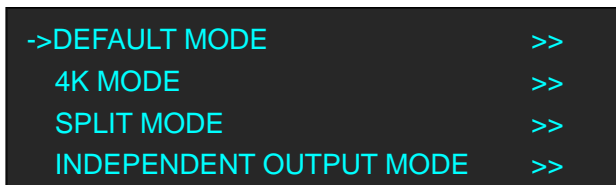

4. Select <DEFAULT MODE> or <4K MODE> according to actual need, push the knob to confirm, and enter to the menu items as follows:

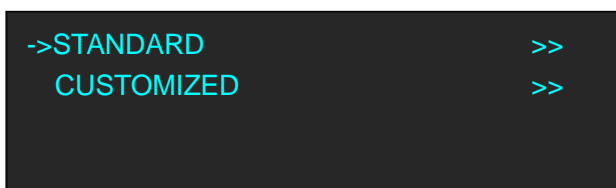

5. Turn the rotary knob, and select <CUSTOMIZED>, push the knob to confirm, and enter to the menu items as follows:

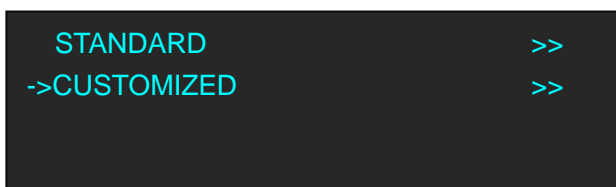



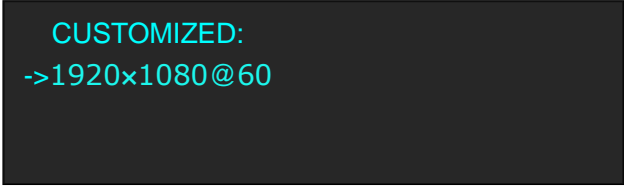

CUSTOMIZED:  
->1920x1080@60

6. Turn the knob on each digital position, and change the value of the digital by the digital buttons on the front panel. For example, input 1536 as following:

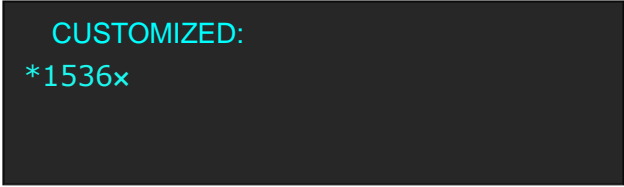

CUSTOMIZED:  
\*1536x

7. After the digital, push the knob will add \*, means before the \* is the horizontal size. Same operation for vertical size, for example input1536 as following:

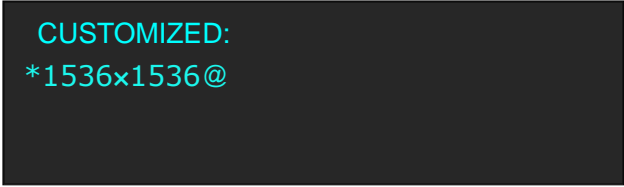

CUSTOMIZED:  
\*1536x1536@

8. After the digital, push the knob will add @, means before the @ is the vertical size, and after the @ is the refresh rate. Only digital 50 or digital 60 supports for the refresh rate. Use the digital buttons to finish the settings, For example, input refresh rate 60:

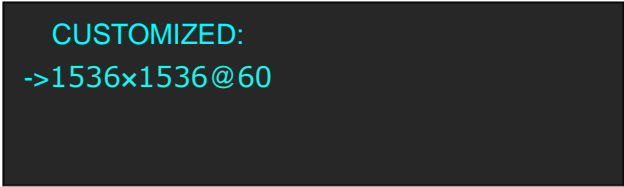

CUSTOMIZED:  
->1536x1536@60

9. After input all the values, push knob to enable VENUS X1PRO to output this resolution. VENUS X1PRO will take 5~10 seconds to enable this output resolution.

## 3.10 User Define Black Key

Default the [BLACK] button as black function. Push the button, its LED light is on, the output will be switched to black, push the button again, its LED light is off, and output the video image.

For more details, please refer to: [Using Black Out](#).

Besides BLACK, user can define this button as FREEZE, TP and BRIGHTNESS, the operations are as follows:

1. Push the [MENU] button, and enter to the menu items, turn the rotary knob, select <SYSTEM>:

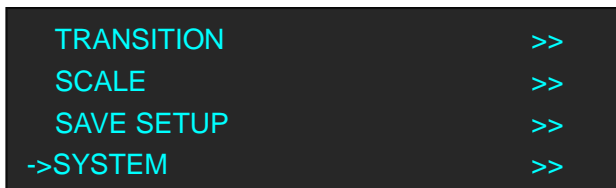

2. Push the knob to confirm, turn the rotary knob, and select <USER DEFINES BUTTON>:

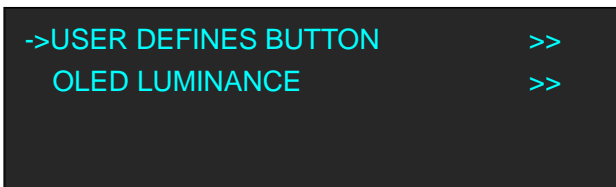

3. Push the knob to confirm, and enter to the menu items as follows:

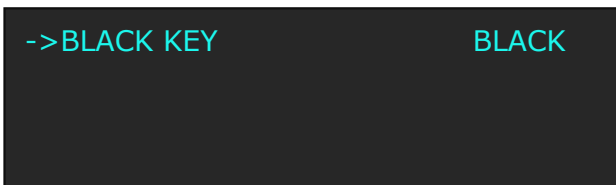

4. Push the knob to confirm, turn the knob, and select <FREEZE>, <TP> or <BRIGHTNESS>, push the rotary knob to confirm.

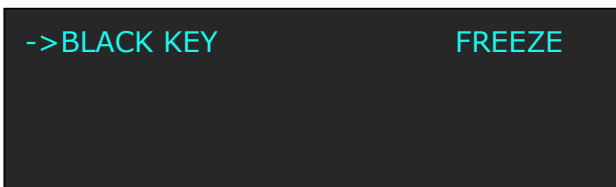

- (1) If select <FREEZE>, push the button, its LED light is on, and freeze the image.

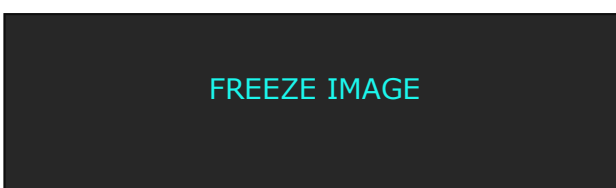

Push the button again, its LED light is off, and output the video image.

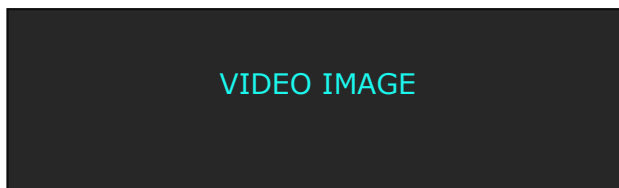

(2) If select <TP>, push the button, its LED light is on, the output will be switched to test pattern.

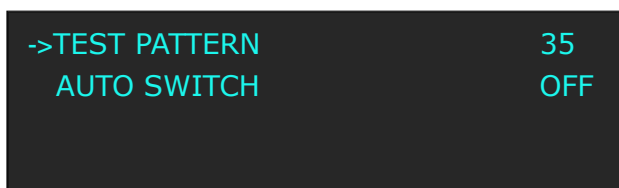

There are 66 kinds of test patterns. If select <AUTO SWITCH>, VENUS X1PRO will output all the test patterns one by one, and the interval between is 1 to10S.

Push the button again, its LED light is off, and output the video image.

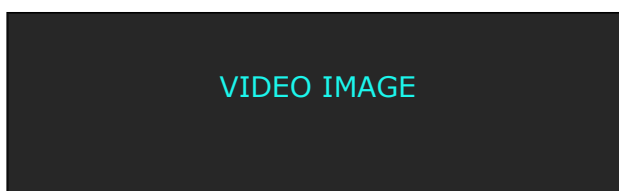

(3) If select <BRIGHTNESS>, push the button, its LED light is on, user can adjust the brightness, contrast, saturation, sharpness, color red, color green, color blue and gamma. If image quality distorts by improper operation, it can be recover by reset.

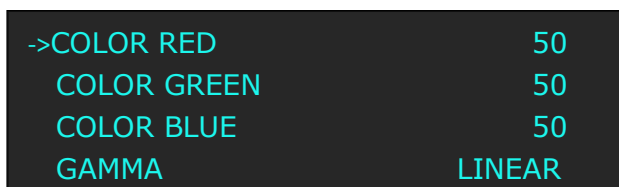
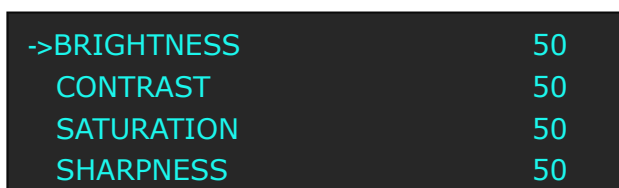

## 3.11 Transition Setting

Push the [MENU] button for two times, and enter to the transition function menus, transition menu shown as follows:

->DEINTERLACE	ON
IMAGE ENHANCE	OFF
MODE	DISSOLVE
PULL SCREEN	OFF
->FADE TIME	0.5s
ALPHA	16

**DEINTERLACE:** Force Deinterlace function, select “ON” or “OFF”.

ON: Force deinterlace.

OFF: No deinterlace.

**IMAGE ENHANCE:** Image enhancement function, for image edge sharpening, color reduction and image scaling.

**MODE:** Special effects switching modes, including DISSOLVE, CUT, WIPE SQUARE IN, WIPE SQUARE OUT, WIPE TOP LEFT IN, WIPE TOP LEFT OUT, WIPE TOP RIGHT IN, WIPE TOP RIGHT OUT, WIPE BOTTOM LEFT IN, WIPE BOTTOM LEFT OUT, WIPE BOTTOM RIGHT IN, WIPE BOTTOM LEFT OUT, WIPE LEFT IN, WIPE LEFT OUT, WIPE RIGHT IN, WIPE RIGHT OUT, WIPE TOP IN, WIPE TOP OUT, WIPE BOTTOM IN and WIPE BOTTOM OUT.

**PULL SCREEN:** Enable or disable pull screen function.

**FADE TIME:** Switch time setting. Turn the rotary knob to select the fade time and push the knob to confirm. The switching time ranges from 0 to 3S.

**ALPHA:** Set the image transparency, the adjustment range is 0 to 16.

## 3.12 Screen Size Setting

VENUS X1PRO supports the screen parameters to meet the requirement where user want to switch between scale screen size and full display size (like monitor). This is only enable for a single display window. Following is an example of a screen size is 1408 x 832.

Operator can defined the VENUS X1PRO output resolution from standard output resolution list or customized the output resolution which is higher than 1408 x 832. For this application 1440x900 is an example:

Push the [MENU] button to go into the main menu, turn the knob and choose <OUTPUT>, push the knob to confirm, turn the knob to choose <SCREEN PARAMETERS>, push the knob and goes into the SCREEN PARAMETERS menus as following:

**H SIZE:** Horizontal pixels, turn the knob or use the digital button to input the value 1408.

**V SIZE:** Vertical pixels, turn the knob or use the digital button to input the value 832.

**H POS:** Horizontal position, default value is 0, set the value as the way of H SIZE and V SIZE.

**V POS:** Vertical position, default value is 0, set the value as the way of H SIZE and V SIZE.

**MODE:** Mode option, select SCREEN SIZE.

**SCREEN FOLLOW SCALE:** User can enable or disable this function. When select "ON", the size of the screen will change according to scale setting

**RESET:** If image quality distorts by improper operation, it can be recover by reset.



## 3.13 Using Black Out

Black out descriptions:

Black signal realizes one-key-touch to a black screen.

VENUS X1PRO provides black effect processing for output with cut black effect. Operation is as below:

Push the [BLACK/0] button, then output will cut to BLACK, shown as below:

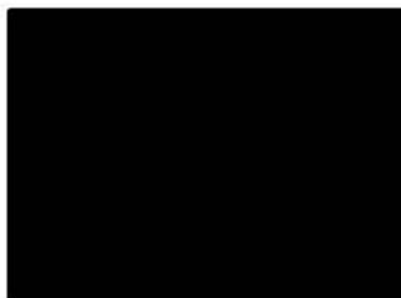

## 3.14 Saving Views

VENUS X1PRO provides 36 positions for saving or recording parameters. To save current parameters and settings:

1. Push the [SAVE/1] button, the button light is on, and enable the SAVE function.

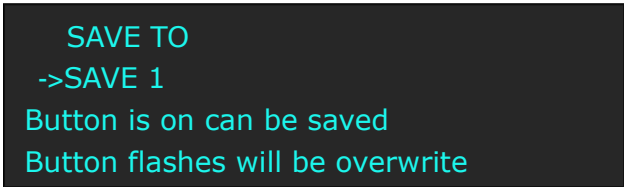

SAVE TO  
->SAVE 1  
Button is on can be saved  
Button flashes will be overwrite

2. Turn the rotary knob, and select the position that will save, push the knob to confirm.
3. The number button 1, 2, 3, 4, 5, 6, 7, 8, 9, 0 means SAVE1~10, push any button on to save. For example,, push number button 2 and save to SAVE 2, the OLED panel will show as follows after saving.

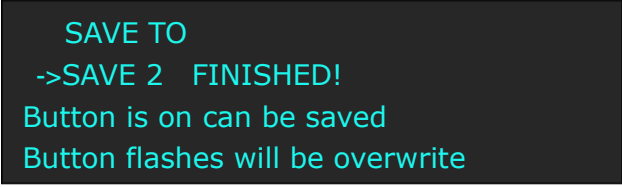

SAVE TO  
->SAVE 2 FINISHED!  
Button is on can be saved  
Button flashes will be overwrite

4. Push the [SAVE/1] button again, the button light is off, and disable the SAVE function.

---

## 3.15 Recall Saved Settings

VENUS X1PRO provides 36 positions for saving or recording parameters. To recall saved settings:

1. Push the [LOAD/6] button, the button light is on, and enable the LOAD function:

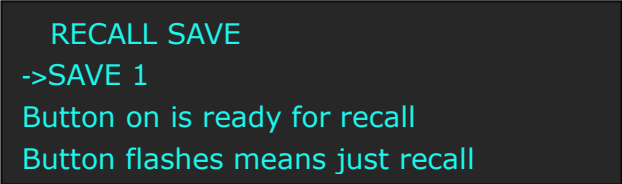

RECALL SAVE  
->SAVE 1  
Button on is ready for recall  
Button flashes means just recall

2. Turn the rotary knob, and select the position that will load, push the knob to confirm.
3. Push the [LOAD/6] button again, the button light is off, and disable the LOAD function.



# Chapter 4 Ordering Codes

---

## 4.1 Product

110-0001-10-0	X1PRO
110-0001-12-0	X1PRO with EXT module fitted
110-0001-11-2	X1PRO with Wi-Fi
110-0001-13-2	X1PRO with EXT & Wi-Fi

## 4.2 Options

### 4.2.1 Input Options

190-0001-02-1	VGA Input 1 × VGA
190-0001-03-1	Display Port Input (DP1.2) 1 × Display Port
190-0001-04-1	DVI Input 1 × DVI
190-0001-05-1	DVI Input /Loop Out 1 × DVI (with loop)
190-0001-06-1	HDMI Input /Loop Out 1 × HDMI (with loop)
190-0001-07-1	3G-SDI Input /Loop Out 1 × SDI (with loop)
190-0001-09-1	CVBS In/Backup 1 × CVBS + CVBS BACKUP
190-0001-10-1	USB In/Backup 1 × USB + USB BACKUP
190-0001-11-1	Audio Management 3 × AUDIO IN + 1 × AUDIO OUT
190-0001-12-0	Wi-Fi Plug In Module 1 × WIFI
190-0001-13-0	RS232 Comm. Module (Standard) 1 × RS232

## 4.2.2 Output Options

190-0001-21-0      Output Expansion Module  
1 × DP + 2 × DVI

## 4.3 Sender Cards

RCRCPJ00090	Linsn TS801
RCRCPJ00091	Linsn TS802
RCRCPJ00110	Nova MSD300
RCRCPJ00112	Nova MSD600
RCRCFJ00133	Colorlight iT7

# Chapter 5 Support

---

## 5.1 Questions and Troubleshooting

### 5.1.1 The Preview Output Problems and Issues

**Q:** The VENUS X1PRO is unable to provide Full Preview Functionality.

**A:** The VENUS X1PRO do not support resolution changing under Normal Model (Preview and Program feature) because of the layout of the design, only can be changed in Independent Model, so if customers would like to realize this feature, they can add one more VENUS X1PRO to change the resolution in the Normal Mode--say the first VENUS X1PRO Output 3 and Output 4 connect to another VENUS X1PRO to change the resolution.

**Q:** It is not able to view an image on the 4:3 19" LCD Preview Monitor Screen and needed to lower the resolution of the Preview Output, in order for an image signal to come through on the screen, to be viewed.

**A:** The VENUS X1PRO has been tested with 4:3 / 19" LCD screen and it is ok, user can use another processor to test in the LCD screen if it is ok or not.

**Q:** User are only able to set or adjust a Preview Output resolution in Independent Mode.

**A:** Yes, this is unchangeable at present because of the software design and layout, otherwise, we need to re-design the whole VENUS X1PRO software, user can add one more VENUS X1PRO, and same solution with the above First question and suggestion.

**Q:** User cannot separately set the Preview Output Resolution in Normal Mode, 4K Mode, Split Mode and Cascade Mode. However, when use the Independent Mode, there is no Take facility/function available, so user cannot preview the sources in this Independent Mode.

**A:** Yes, this is unchangeable at present because of the software design and layout, otherwise, we need to re-design the whole VENUS X1PRO software, user can add one more VENUS X1PRO, and same solution with the above First question and suggestion.

**Q:** When user apply/adjust/set the lower resolution for the Preview Output (in Independent Mode), this lower resolution set/applied for Preview is also sent out/applied to the Program Output as well.

**A:** Reset the Preview resolution.

**Q:** The only way we are able to view/preview the sources on the Preview Monitor Screen, is within Normal Mode, by selecting a 1024x768@50Hz Resolution Setting.

**A:** In Normal Mode, all the output resolution is same, if customer need different resolution, we suggest to change to other Mode which can be realized.

**Q:** During setup, the system is powered down, then powered back up, but these settings are somehow lost.

**A:** Please confirm if customer has successfully saved to SAVE 1.

**Q:** As indicated in all product literature information, with the inclusion of the optional Output Expansion Card/Module provides for "Full Preview" functionality. This "***should***" include the ability to independently control/set/adjust the Output Resolution for Preview, although not very commonly required.

**A:** Use two more output as Options can save more cost for the customer, since some customer only need standard two output is enough and do not need to pay more extra cost, that is why we have this design.

**Q:** In Normal Mode, there is no access to control/set/adjust the Output Resolution on/for DVI Output 3 and DVI Output 4 on the Output Expansion Module, however, Output Resolutions can be set/adjusted on all other Modes, why is this?

**A:** In Normal Mode, all Output resolution is same, and can't be changed, which is also collected from our other customers as well as software design and layout, if customer do not set and adjust the same resolution, they can use other models.

**Q:** An "Auto Adapt" function to provide a full screen image, there is no such feature that appeared to be functioning.

**A:** Yes, we also not mention that this is the feature of processor. LCD display and projector can "Auto Adapt" the resolution if signal connected to them, but for LED, it is different, LED need to be scalable and positioning, can not auto adapt the resolution and position in the LED screen, this is about the difference of LED and LCD, it is not about processors.

**Q:** On the Program Output Resolutions in Normal Mode of either 1920x1080, or 1920x768, or even as low as 1024x768, all at 50Hz, the image is not very stable, every 60 to 90 odd seconds the image would flicker.

**A:** If have connected the VENUS X1PRO to Projector or Monitor, please check the HDMI to CAT 5 cable, maybe it is the transmitting problem. Suggest use the resolution 60Hz, since 60Hz is far more stable than 50Hz.

**Q:** If select a 3840x2160 resolution, and the image is stable and held perfectly, however, it is unstable for a simpler, lower resolution.

**A:** The 3840x2160 is 4Kx60Hz, not 50Hz, each output is 1920x1080x60Hz, but in the Previous Point, it is 50Hz, so please check the connection as well as the HDMI to CAT5 transmitting issue.

## 5.2 Contact Us



**Phone**  
+86-592-577-1197

**Email**  
Sales [sales@rgblink.com](mailto:sales@rgblink.com)  
Support [support@rgblink.com](mailto:support@rgblink.com)

### Social Media



@RGLINK



/rgblink



+rgblink



/rgblink



rgblink

# Chapter 6 Appendix

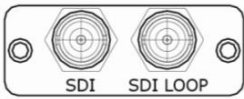

## 6.1 Specification

<b>DVI Input (Standard)</b>	
Number of Inputs	1
Connector	Standard DVI-I socket
Supported Resolution	SMPTE: 625/25/50 PAL, 525/29.97/59.94 NTSC, 1080P50/59.94/60   1080i50/59.94/60, 720p50/59.94/60 VESA: 800×600@60   1024×768@60   1280×768@60   1280×1024@60   1600×1200@60   1920×1080@60
Signal Level	TMDS pwl, single pixel input,165MHz bandwidth
Format Standard	HDMI 1.3
<b>VGA Input (Standard)</b>	
Number of Inputs	1
Connector	Standard DB15 Socket
Supported Standard	VGA-UXGA
Signal Level	R, G, B, Hsync, Vsync: 0 to1Vpp±3dB (0.7V Video+0.3v Sync ) 75 ohm black level: 300mV Sync-tip: 0V
Supported Resolution	VGA-UXGA (800×600@60   1024×768@60   1280×1024@60   1440×900@60   1600×1200@60)
<b>DP Input (Standard)</b>	
Number of Inputs	1
Connector	Standard
Supported Resolution	VESA: 3840×2160×24   3840×2160×25   3840×2160×30   4096×2160×24 SMPTE: 625/25/50 PAL, 525/29.97/59.94 NTSC, 1080P50/59.94/60   1080i50/59.94/60, 720p50/59.94/60
Supported Bandwidth	21.6Gb/s
Format Standard	DP 1.2
<b>HDMI Input (Standard)</b>	
Number of Inputs	1
Connector	Standard HDMI-A socket
Supported Resolution	VESA: 3840×2160×24   3840×2160×25   3840×2160×30   4096×2160×24 SMPTE: 625/25/50 PAL, 525/29.97/59.94 NTSC, 1080P50/59.94/60   1080i50/59.94/60, 720p50/59.94/60
Signal Level	TMDS pwl,single pixel input,165MHz bandwidth
Format Standard	HDMI 1.4

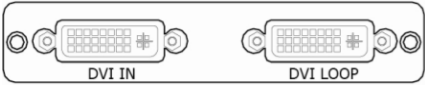

<b>HDMI Loop Out (Standard)</b>	
Number of Loop Out	1
Connector	Standard DVI-I socket
Supported Resolution	VESA: 3840×2160×24   3840×2160×25   3840×2160×30   4096×2160×24 SMPTE: 625/25/50 PAL, 525/29.97/59.94 NTSC, 1080P50/59.94/60   1080i50/59.94/60, 720p50/59.94/60
Signal Level	TMDS pwl, single pixel input,165MHz bandwidth
Format Standard	HDMI 1.4
<b>DVI Output (Standard)</b>	
Number of Outputs	2
Connector	Standard DVI-I Socket
Signal Level	TMDS pw, 165MHz bandwidth
Supported Resolution	SMPTE: 625/25/50 PAL, 525/29.97/59.94 NTSC, 1080P50/59.94/60   1080i50/59.94/60, 720p50/59.94/60 1280×720@23.98   1280×720@24   1280×720@25   1280×720@29.97   1280×720@30   1920×1080@23.98   1920×1080@24   1920×1080@25   1920×1080@29.97   1920×1080@30 VESA: 800×600@60   1024×768@60   1024×768@75   1280×720@60   1280×720@50   1280×768@60   1280×800@60   1280×1024@60   1360×768@60   1366×768@60   1400×1050@60   1440×900@60 1600×1200@60   1680×1050@60   1920×1080@60   1920×1080@50   1920×1200@60   2048×1152@60   2560×812@60   2560×816@60   1536×1536@60
<b>DP Output (Standard)</b>	
Number of Outputs	1
Connector	Standard
Supported Resolution	VESA: 3840×2160×24   3840×2160×25   3840×2160×30   4096×2160×24 SMPTE: 625/25/50 PAL, 525/29.97/59.94 NTSC, 1080P50/59.94/60   1080i50/59.94/60, 720p50/59.94/60
Supported Bandwidth	21.6Gb/s
Format Standard	DP 1.2
<b>3G-SDI Input (SDI optional module)</b>	
Interface Appearance	
Board Size	52(L)×19.5(W) (mm)
3G-SDI Input	
Number of Inputs	3

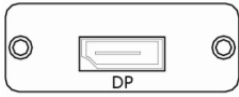
Connector	Standard BNC Socket
Data Rate	2.97Gb/s, 2.97/1.001Gb/s, 1.485Gb/s, 1.485/1.001Gb/s and 270Mb/s
Supported Standard	SMPTE 425M - 3G Level A and Level B Formats
Supported Resolution	SMPTE 425M (3G Level A) 4:2:2: 1920×1080/60 (1:1)   1920×1080/50 (1:1). SMPTE 425M (3G Level B DS1 and DS2) 4:2:2: 1920×1080/60 (2:1)   1920×1080/50 (2:1) SMPTE 296M (HD): 1280×720/50 (1:1)   1280×720/50 (1:1) SMPTE 125M (SD): 1440×487/60 (2:1)   525-line 487 generic SMPTE ITU-R BT.656 (SD): 1440×576/50 (2:1), 625-line generic.
Balance	Belden 1694A cable: 150m at 2.97Gb/s 250m at 1.485Gb/s 480m at 270Mb/s
<b>SDI Loop Out</b>	
Number of Loop Out	3
Connector	Standard BNC Socket
Data Rate	2.97Gb/s, 2.97/1.001Gb/s, 1.485Gb/s, 1.485/1.001Gb/s and 270Mb/s
Supported Standard	SMPTE 425M - 3G Level A and Level B Formats
Supported Resolution	SMPTE 425M (3G Level A) 4:2:2: 1920×1080/60 (1:1)   1920×1080/50 (1:1). SMPTE 425M (3G Level B DS1 and DS2) 4:2:2: 1920×1080/60 (2:1)   1920×1080/50 (2:1) SMPTE 296M (HD): 1280×720/50 (1:1)   1280×720/50 (1:1) SMPTE 125M (SD): 1440×487/60 (2:1), 525-line 487 generic SMPTE ITU-R BT.656 (SD): 1440×576/50 (2:1), 625-line generic.
Balance	Belden 1694A cable: 150m at 2.97Gb/s 250m at 1.485Gb/s 480m at 270Mb/s
<b>DVI IN+DVI LOOP (DL optional module)</b>	
Interface Appearance	
Board Size	104.5(L)×19.5(W) (mm)
<b>DVI Input</b>	
Number of Inputs	1
Connector	Standard DVI-I socket
Supported Resolution	SMPTE: 625/25/50 PAL, 525/29.97/59.94 NTSC, 1080P50/59.94/60   1080i50/59.94/60, 720p50/59.94/60

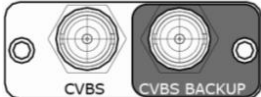

	VESA: 800×600@60   1024×768@60   1280×768@60   1280×1024@60   1600×1200@60   1920×1080@60
Signal Level	TMDS pwl, single pixel input,165MHz bandwidth
Format Standard	HDMI 1.3
DVI Loop out	
Number of Loop Out	1
Connector	Standard DVI-I socket
Supported Resolution	SMPTE: 625/25/50 PAL, 525/29.97/59.94 NTSC, 1080P50/59.94/60,1080i50/59.94/60, 720p50/59.94/60 VESA: 800×600@60   1024×768@60   1280×768@60   1280×1024@60   1600×1200@60   1920×1080@60
Signal Level	TMDS pwl, single pixel input,165MHz bandwidth
Format Standard	HDMI 1.3
<b>DP Input (DP optional module)</b>	
Interface Appearance	
Board Size	52(L)×19.5(W) (mm)
Number of Inputs	1
Connector	Standard
Supported Resolution	VESA: 3840×2160×24   3840×2160×25   3840×2160×30   4096×2160×24 SMPTE: 625/25/50 PAL, 525/29.97/59.94 NTSC, 1080P50/59.94/60   1080i50/59.94/60, 720p50/59.94/60
Supported Bandwidth	21.6Gb/s
Format Standard	DP1.2
<b>HDMI IN+HDMI LOOP (HL optional module)</b>	
Interface Appearance	
Board Size	52(L)×19.5(W) (mm)
HDMI Input	
Number of Inputs	3
Connector	Standard HDMI-A socket
Supported Resolution	SMPTE: 625/25/50 PAL, 525/29.97/59.94 NTSC, 1080P50/59.94/60   1080i50/59.94/60, 720p50/59.94/60 VESA: 800×600@60   1024×768@60   1280×768@60   1280×1024@60   1600×1200@60   1920×1080@60
Signal Level	TMDS pwl, single pixel input,165MHz bandwidth
Format Standard	HDMI 1.3

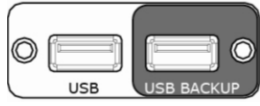
<b>HDMI Loop Out</b>	
Number of Loop Out	3
Connector	HDMI standard type A interface
Supported Resolution	SMPTE: 625/25/50 PAL, 525/29.97/59.94 NTSC, 1080P50/59.94/60   1080i50/59.94/60, 720p50/59.94/60 VESA: 800×600@60   1024×768@60   1280×768@60   1280×1024@60   1600×1200@60   1920×1080@60
Format Standard	HDMI 1.3
<b>DVI Input (DVI optional module)</b>	
Interface Appearance	 A DVI-I connector with a grid of pins and two circular ports on either side. The label "DVI" is centered below the connector.
Board Size	52(L)×19.5(W) (mm)
Number of Inputs	3
Connector	Standard DVI-I socket
Supported Resolution	SMPTE: 625/25/50 PAL, 525/29.97/59.94 NTSC, 1080P50/59.94/60   1080i50/59.94/60, 720p50/59.94/60 VESA: 800×600@60   1024×768@60   1280×768@60   1280×1024@60   1600×1200@60   1920×1080@60
Signal Level	TMDS pwl, single pixel input,165MHz bandwidth
Format Standard	HDMI 1.3
<b>CVBS Input (CVBS optional module)</b>	
Interface Appearance	 Two BNC connectors. The left one is labeled "CVBS" and the right one is labeled "CVBS BACKUP".
Board Size	52(L)×19.5(W) (mm)
Number of Inputs	3
Connector	Standard BNC Socket
Supported Standards	PAL/NTSC
Signal Level	1Vpp±3db (0.7V Video+0.3v Sync ) 75 ohm
Multiplex	480i,576i
<b>VGA Input (VGA optional module)</b>	
Interface Appearance	 A standard 15-pin D-sub connector with a central ground pin. The label "VGA" is centered below the connector.
Board Size	52(L)×19.5(W) (mm)
Number of Inputs	3
Connector	Standard DB15 Socket
Supported Standard	VGA-UXGA
Signal Level	R、G、B、Hsync、Vsync:0 to1Vpp±3dB (0.7V Video+0.3v Sync ) 75 ohm

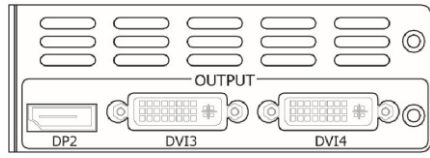
	black level: 300mV Sync-tip: 0V
Supported Resolution	VGA-UXGA (800×600@60   1024×768@60   1280×1024@60   1440×900@60   1600×1200@60)
<b>USB Input (USB optional module)</b>	
Interface Appearance	
Board Size	52(L)×19.5(W) (mm)
Number of Inputs	3
Connector	Standard USB port
Supported Standard	Support general Image and video formats
<b>Audio Input (Audio optional module)</b>	
Interface Appearance	
Board Size	52(L)×19.5(W) (mm)
Audio Input	
Number of Inputs	3
Connector	Standard RCA Socket
Audio Standard	48Kbps 24bit
Audio Output	
Number of Outputs	1
Connector	Card faucet , Standard 1/4 Socket
Audio standard	48Kbps 24bit
<b>Output Expansion Module</b>	
Interface Appearance	
Board Size	115(L)×39.9(W) (mm)
DP Output	
Number of Outputs	1
Connector	Standard
Supported Resolution	Support resolution: WQXGA + (1920 x 1200), and color depth: 30/36 bit (each primary 10/12 bit)
Supported Bandwidth	21.6Gb/s
Format Standard	DP 1.2
DVI Output	
Number of Outputs	2
Connector	Standard DVI-I Socket
Signal Level	TMDS pw, 165MHz bandwidth

Supported Resolution	SMPTE: 625/25/50 PAL, 525/29.97/59.94 NTSC, 1080P50/59.94/60   1080i50/59.94/60, 720p50/59.94/60 1280×720@23.98   1280×720@24   1280×720@25   1280×720@29.97   1280×720@30   1920×1080@23.98   1920×1080@24   1920×1080@25   1920×1080@29.97   1920×1080@30 VESA: 800×600@60   1024×768@60   1024×768@75   1280×720@60   1280×720@50   1280×768@60   1280×800@60   1280×1024@60   1360×768@60   1366×768@60   1400×1050@60   1440×900@60 1600×1200@60   1680×1050@60   1920×1080@60   1920×1080@50   1920×1200@60   2048×1152@60   2560×812@60   2560×816@60   1536×1536@60
<b>WiFi Hotspot Module</b>	
Certification	FCC/CE
Wireless Standard	802.11 b/g/n
Frequency range	2.412GHz-2.484GHz
Transmit Power	802.11b: +20dBm (Max.)
	802.11g: +18dBm (Max.)
	802.11n: +15dBm (Max.)
	Configurable
Receiver Sensitivity	802.11b: -89dBm
	802.11g: -81dBm
	802.11n: -71dBm
Antenna Option	External: I-PEX Connector
<b>Function</b>	
Input channel configuration	Support each input channel signal programming configuration
PIP	Support PIP、PBP for any two inputs
Transition effects	Fade in and fade out switching between any two inputs
<b>Extras</b>	
Communication	RS232 USB TCP/IP
Power Supply	85-264V IEC-3
Working Environment	0°C~45°C
Stored Environment	10% to 90%
Product Warranty	3 years parts and labor warranty

## 6.2 Software Upgrade

**Please install the USB to serial drive before upgrading the software**

|VCP\_V1.3.1\_Setup\_x64.exe -64 bit and VCP\_V1.3.1\_Setup\_X32.exe -32 bit.

### 1. Connect the device and computer

Connect the USB interface of VENUS X1PRO to the computer with a USB cable (USB-A to USB-B), as shown in Figure 1 and Figure 2.



Figure 1 USB Cable (USB-A to USB-B)



Figure 2 CONT Interface

### 2. Get the COM Port

Right click "My computer" icon → Device manager, and get the COM Port (COM \*), as shown in the figure below:



Figure 3 COM Port

### 3. Load the program files

Double click the upgrade tools (support Windows system), and click the icon  , pop-up the setting interface as follows. Select the COM port (same with step 2), and set baudrate as 115200, click “OK”.



Figure 4 Upgrade Tool Interface

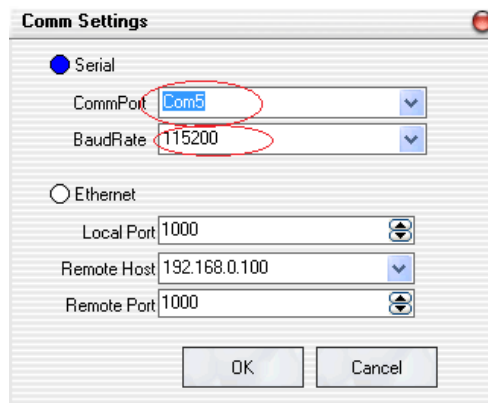



Figure 5 Serial Setting

Click “Select Files” (Mark 2), and select the .bin file in “VENUS X1PRO\_Firmware → Firmware Package → X1PRO package\_100M V1.X”.

The .bin file in VENUS X1PRO package\_100M V1.X is a package, which includes 6 subprogram.

Click  (Mark 4) to select all program files, then click “Upgrade” (Mark 5) to start upgrade.

After upgrading, it will display “Upgrade Successfully”, and the progress bar shows “100%”.

If select one of the program files, click the corresponding subprogram, and click “Upgrade” behind it. Same as above, it will display “Upgrade Successfully”, and the progress bar shows “100%” after upgrading.

4. The upgrade progress is about 2~3 minutes.

5. Plug into the power cord after upgrading, and factory reset. Restart the device again and ensure the new program can operate normally.

**Note:**

**The device will prompt “Restart the device” after upgrading. When restart for the first time, it**

**will check and program the procedure to the MCU. This process will takes about 10 seconds. During program, the OLED display and buttons are uncontrolled.**

## 6.3 Installing Options

### 6.3.1 Installing Input Module

VENUS X1 and VENUS X1PRO is based on replaceable input optional modules structure, user can install or replace the optional module according to actual need. Take VENUS X1 for example, the specific installation steps are as follows:

#### Install the Optional Module

1. Unscrew the 2 captive screws in input modules block, and pull out the input module block, as shown in figure:

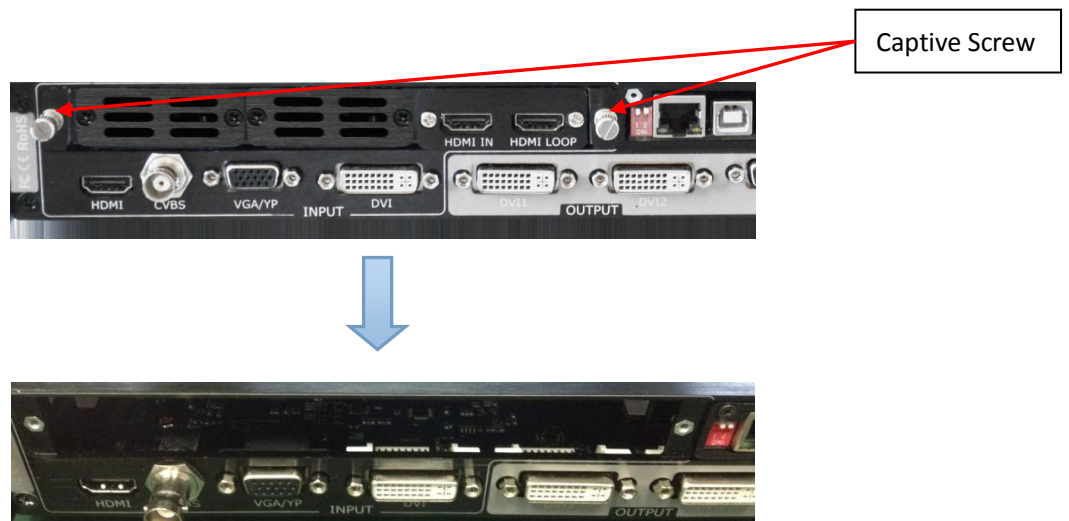

2. Fix the input EXT board and input modules on the plate with the fixed screws, as shown in figure:

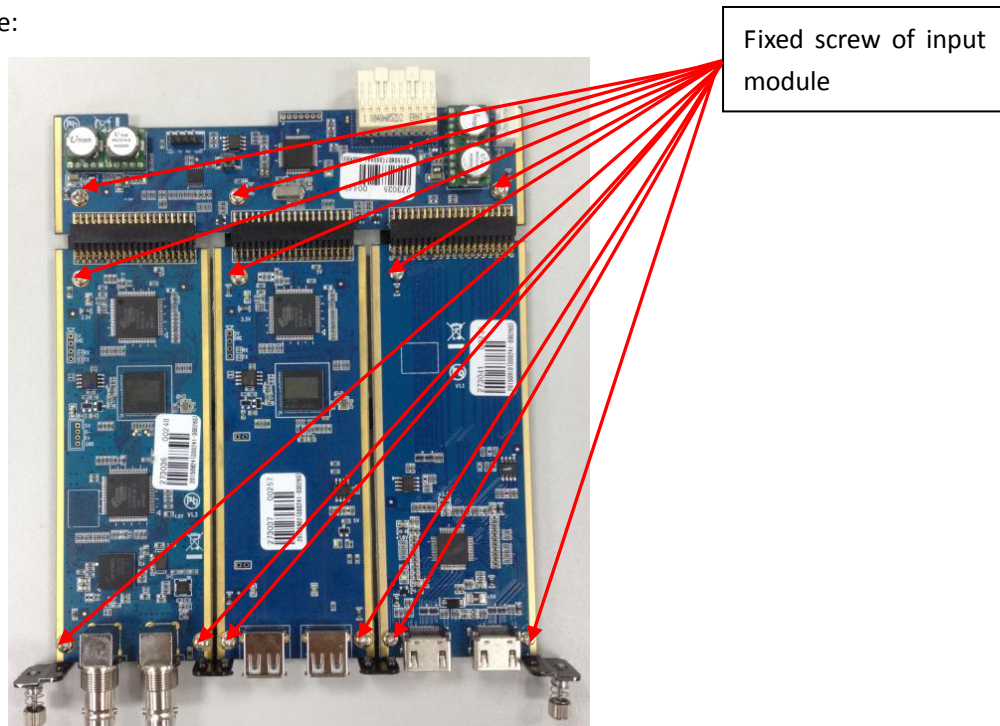



3. Push the input modules into the device along the slide rail, and screw the captive screws, then install the input blocks, as shown in figure:



4. If install the SDI input module, please screw the SDI interface, as shown in figure:



5. Lock the input blocks, as shown in figure:



### Replace the Optional Module

1. Unscrew the captive screws, and pull out the input modules that will replace, as shown in figure:



Captive Screw

2. Unscrew the fixed screws of input module, as shown in figure:

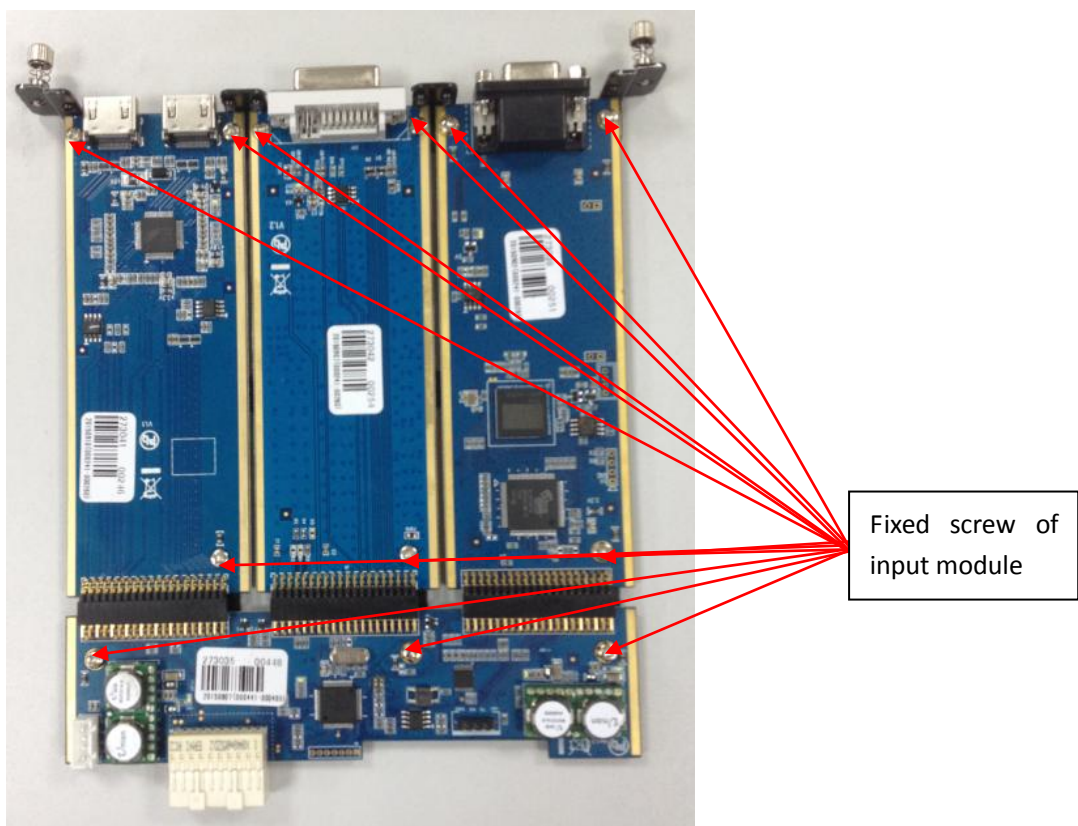

Fixed screw of input module

3. Take out the input modules that will replace, as shown in figure:

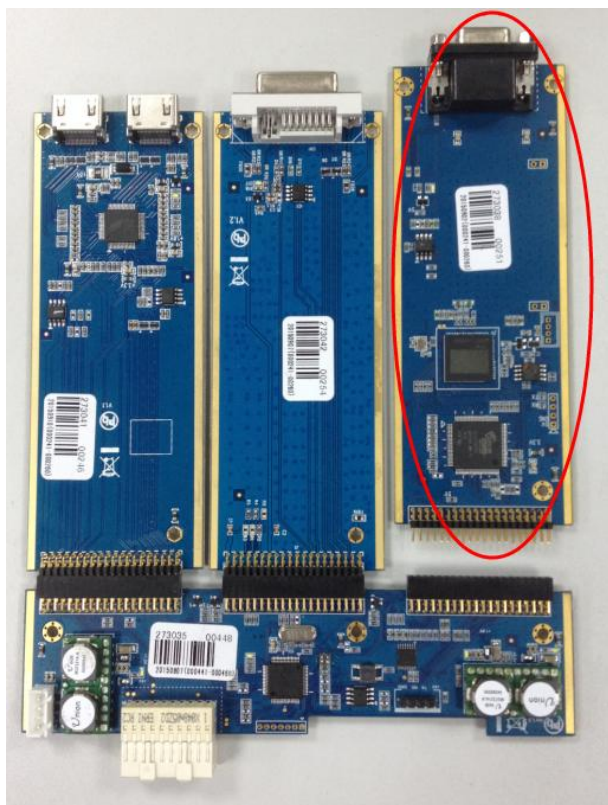

4. Install the input module that user need, as shown in figure:

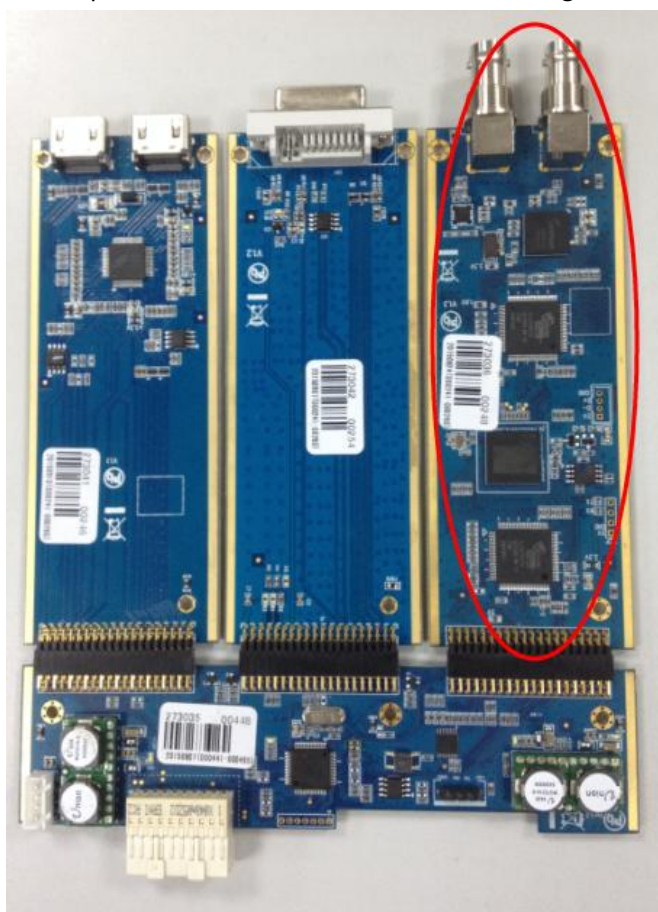

5. Fix the input modules on the plate with screws, as shown in figure:



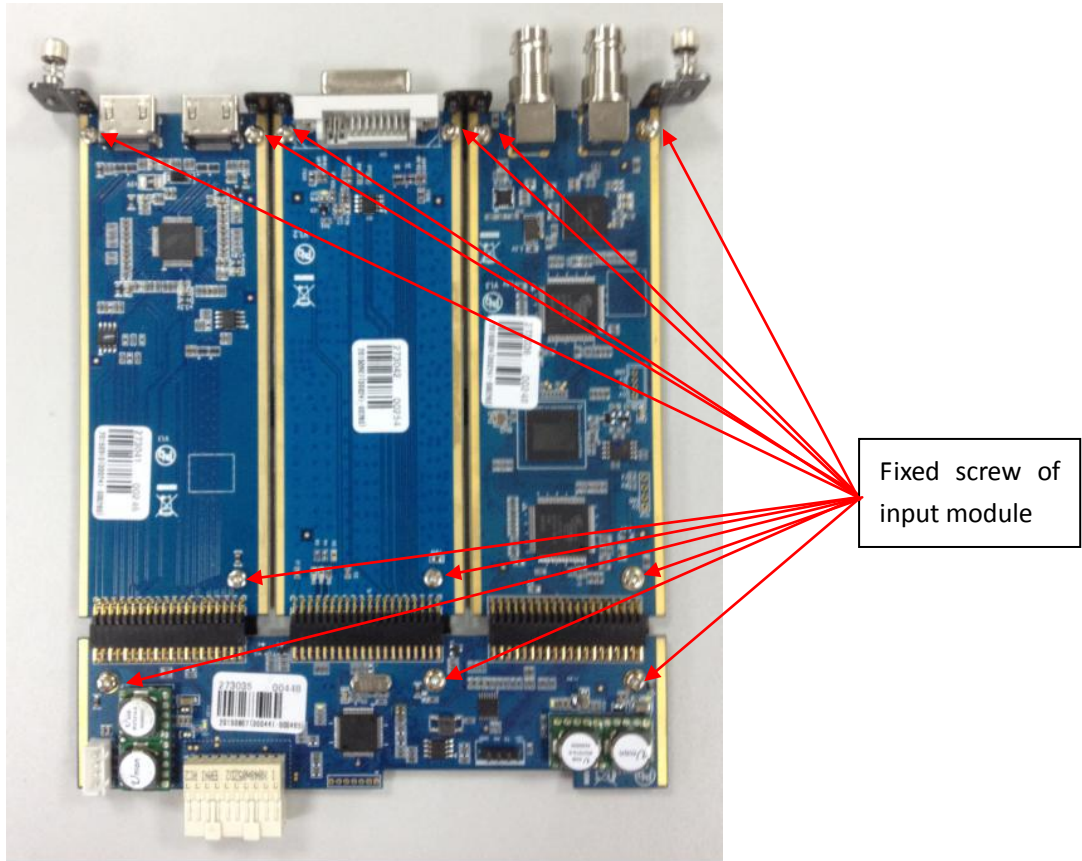

6. Push the input modules into the device along the slide rail, and screw the captive screws, as shown in figure:

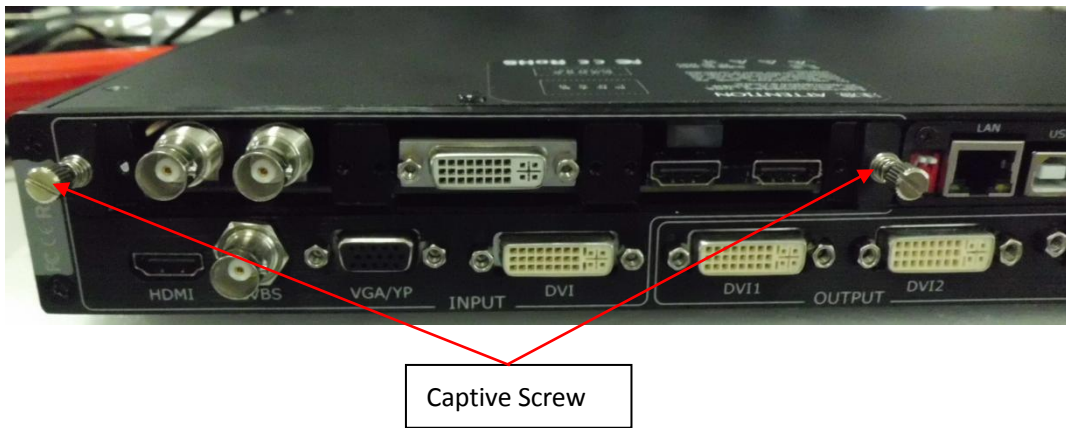

7. Lock the input block, as shown in figure:



## 6.3.2 Installing Output Module

1. Remove the 5 screws on the top cover, and move the top cover, as shown in the figure below:



2. Unscrew the screws and move the sender card way block and holder, as shown in the figure below:

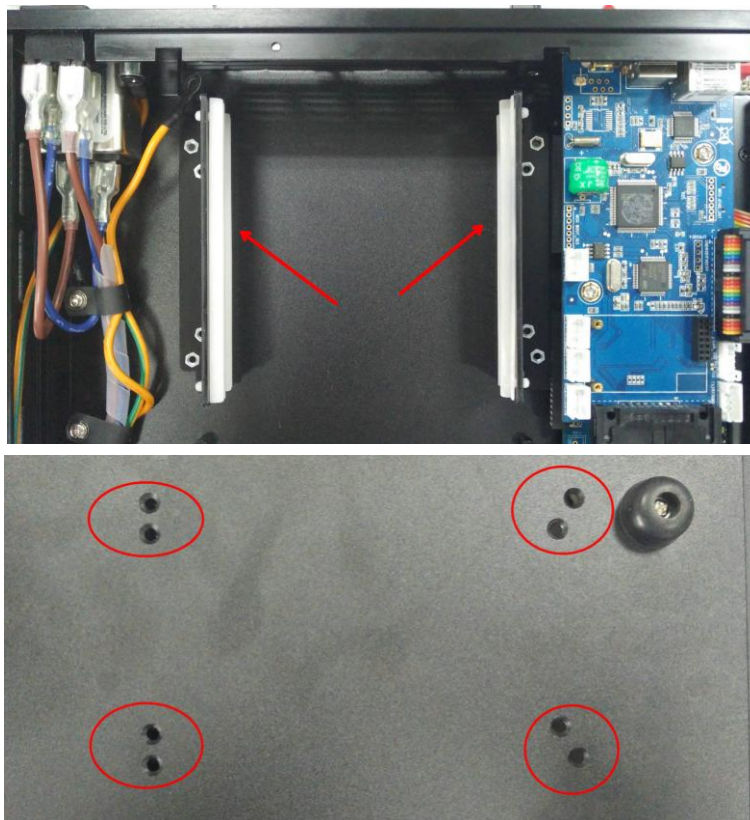



3. Unscrew the captive screws in output modules block, as shown in the figure below:



Captive screw

4. Aligning the mainboard of the output module as shown in the figure below, then lock it with 4 pieces of 3\*5 round head screws.

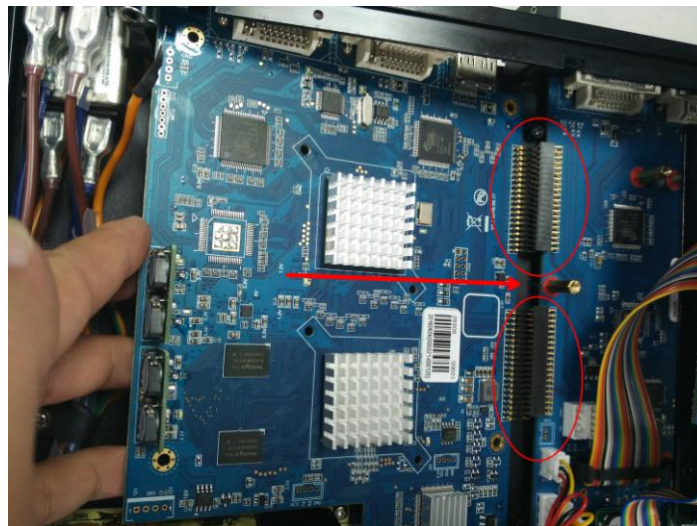



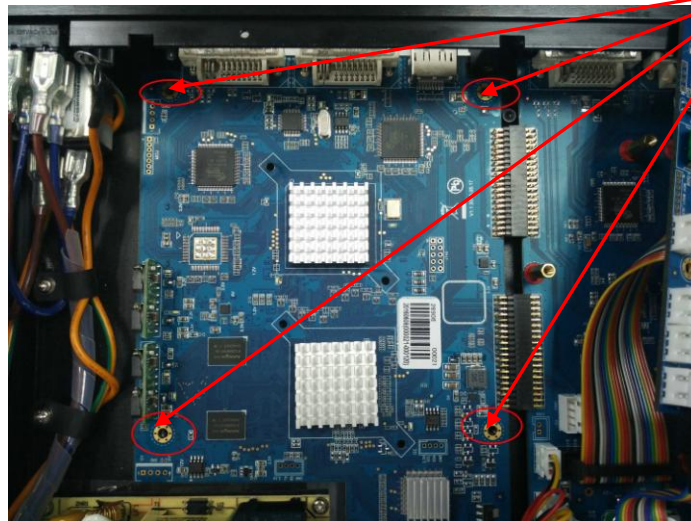

3\*5 round head screw

5. Lock the holder with 4 pieces of flat head screw, and lock to the DVI base with 4 pieces of 6+7 hex nuts.



6. Lock the top cover with 5 screws, and installing Output module is finished.

### 6.3.3 Installing WIFI Module

1. Remove the 5 screws on the top cover, and move the top cover, as shown in the figure below:



2. Install the WIFI module as shown in the figure below: lock the WIFI module with 2 pieces of 2\*5 flat head screws, then connect the antenna junctor and the connector with the WIFI antenna cable.

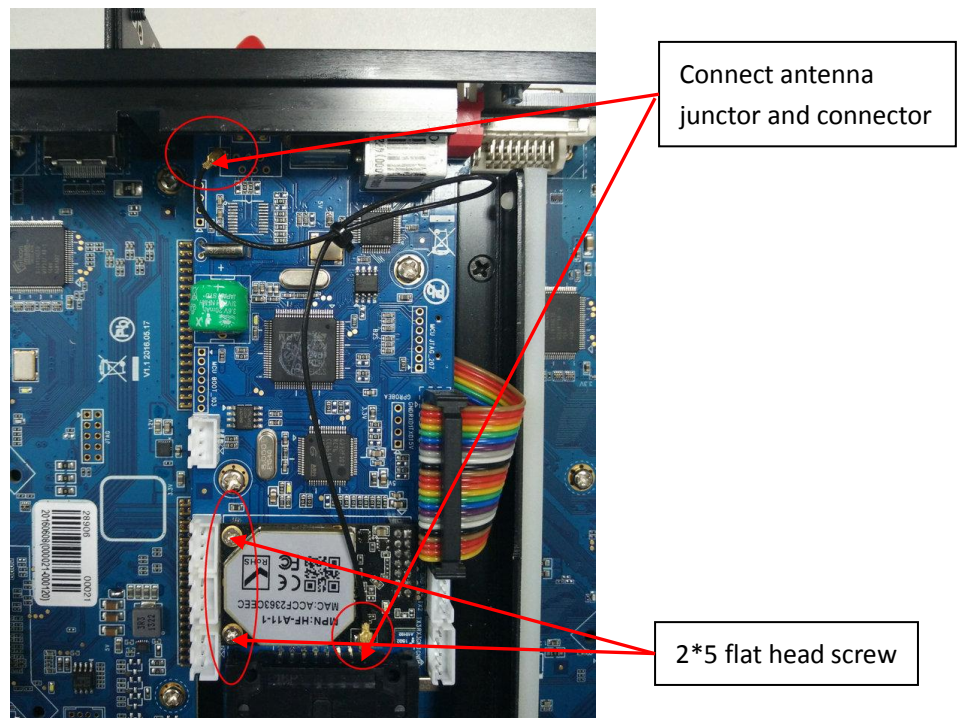

3. Install the external WIFI antenna, as shown in the figure below:



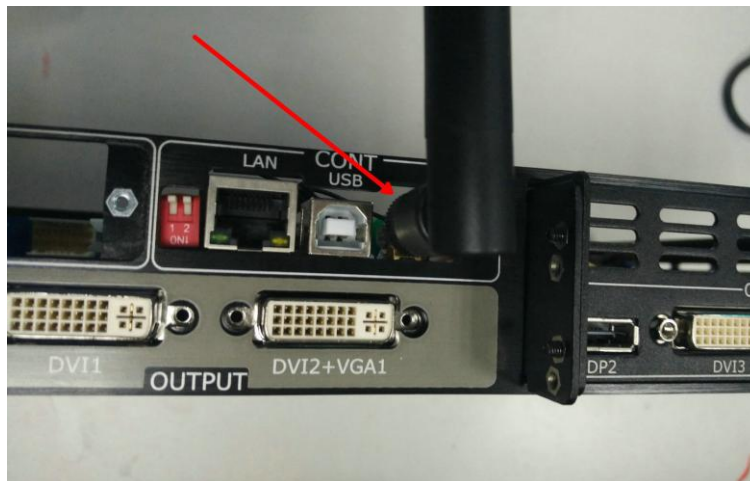

4. Lock the top cover with 5 screws, and installing WIFI module is finished.

## 6.4 Connect WIFI

1. Plug VENUS X1PRO into the power cord, and turn the power switch on the rear of the product to the ON position.
2. Right click the wireless icon on the lower right corner, and select “Wireless Network Connection”, then select “VENUS-X1-0048”, and click “Connect”.

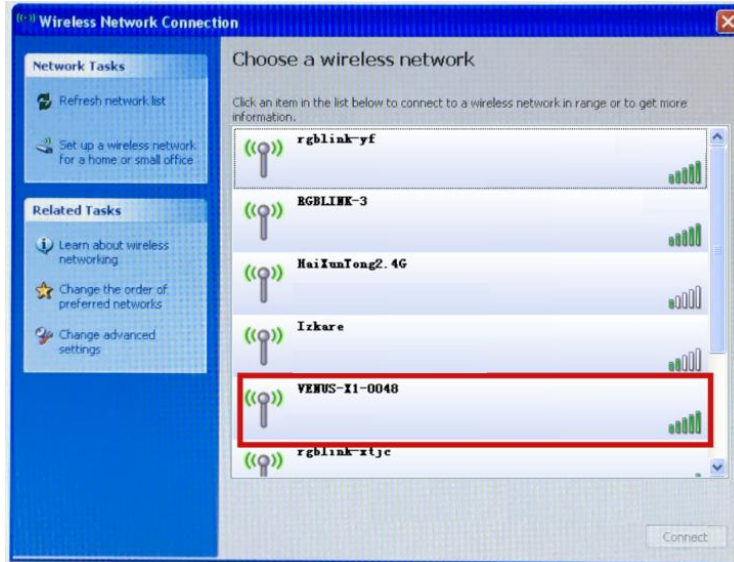

3. Install VENUS X1 windows control program, there will be a new shortcut icon on



the desk after installation, double click the shortcut icon, and enter to the software interface.

4. Click the “Comm Setup” icon, as shown in the figure below:

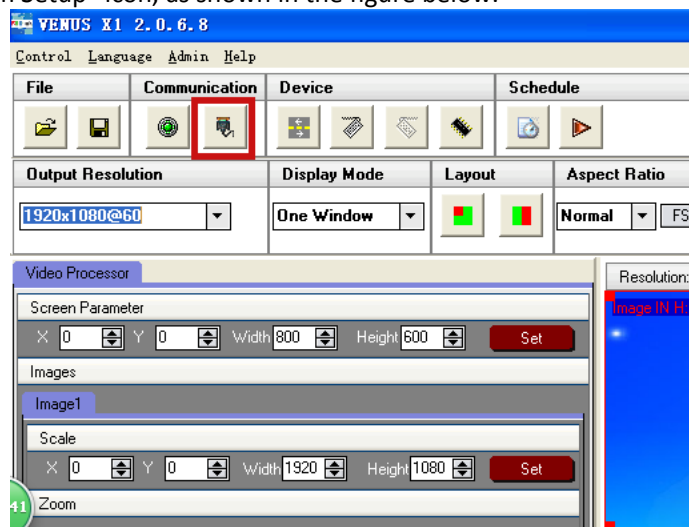

5. It will pop up the comm settings widow, select “Wifi” and click “OK”, as shown in the figure below:

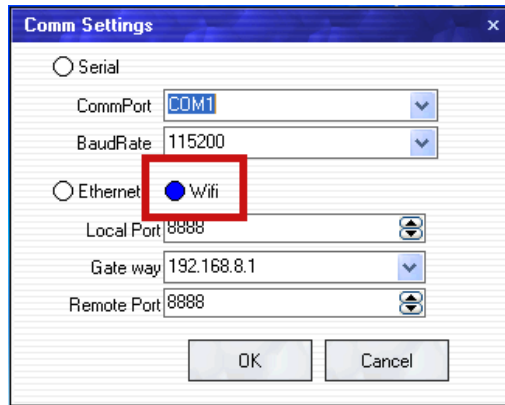

6. The log area will synchronization data, as shown in the figure below:

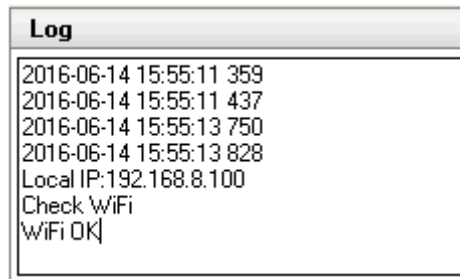

7. If it shown "WiFi OK", click the "Open Comm" icon, as shown in the figure below, and Wifi is connected.

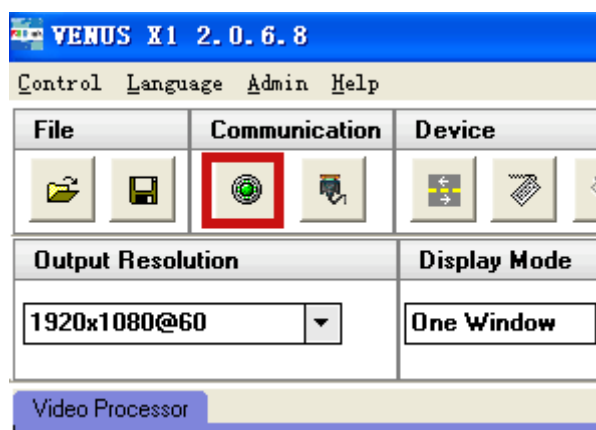
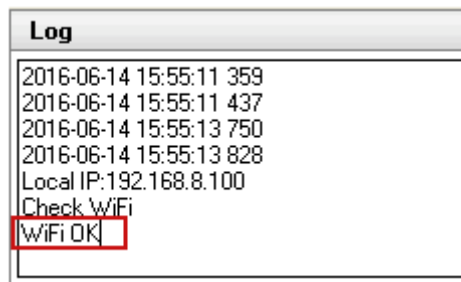

## 6.5 Terms & Definitions

The following terms and definitions are used throughout this guide.

- **“ASCII”**: American Standard for Information Interchange. The standard code consisting of 7-bit coded characters (8 bits including parity check) used to exchange information between data processing systems, data communication systems, and associated equipment. The ASCII set contains control characters and graphic characters.
- **“Aspect ratio”**: The relationship of the horizontal dimension to the vertical dimension of an image. In viewing screens, standard TV is 4:3, or 1.33:1; HDTV is 16:9, or 1.78:1. Sometimes the “:1” is implicit, making TV = 1.33 and HDTV = 1.78.
- **“AV”**: Audio visual, or audio video.
- A **“Background”** is an unscaled source, typically originating from a computer. A background source appears at the system’s lowest priority — visually in back of all other sources.
- **“Baudrate”**: Named of J.M.E. Baudot, the inventor of the Baudot telegraph code. The number of the electrical oscillations per second, called baud rate. Related to, but not the same as, transfer rate in bits per second (bps).
- **“Blackburst”**: The video waveform without the video elements. It includes the vertical sync, horizontal sync, and the chroma burst information. Blackburst is used to synchronize video equipment to align the video output. One signal is normally used to set up an entire video system or facility. Sometimes it is called House sync.
- **“BNC”**: Bayonet Neill-Concelman. A cable connector used extensively in television and named for its inventors. A cylindrical bayonet connector that operates with a twist-locking motion. To make the connection, align the two curved grooves in the collar of the male connector with the two projections on the outside of the female collar, push, and twist. This allows the connector to lock into place without tools.
- **“Brightness”**: Usually refers to the amount or intensity of video light produced on a screen without regard to color. Sometimes called “black level.
- **“CAT 5”**: Category 5. Describes the network cabling standard that consists of four unshielded twisted pairs of copper wire terminated by RJ-45 connectors. CAT 5 cabling supports data rates up to 100 Mbps. CAT 5 is based on the EIA/TIA 568 Commercial Building Telecommunications Wiring Standard.
- **“Color bars”**: A standard test pattern of several basic colors (white, yellow, cyan, green, magenta, red, blue, and black) as a reference for system alignment and testing. In NTSC video, the most commonly used color bars are the SMPTE standard color bars. In PAL video, the most commonly used color bars are eight full field bars. In the computer, the most commonly used color bars are two rows of reversed color bars.
- **“Color burst”**: In color TV systems, a burst of subcarrier frequency located on the back porch of the composite video signal. This serves as a color synchronizing signal to establish a frequency and phase reference for the chroma signal. Color burst is 3.58 MHz for NTSC and 4.43 MHz for PAL.
- **“Color temperature”**: The color quality, expressed in degrees Kelvin(K), of a light source. The higher the color temperature, the bluer the light. The lower the temperature, the

- redder the light. Benchmark color temperature for the A/V industry include 5000°K, 6500°K, and 9000°K.
- **“Contrast ratio”**: The ratio of the high light output level divided by the low light output level. In theory, the contrast ratio of the television system should be at least 100:1, if not 300:1. In reality, there are several limitations. In the CRT, light from adjacent elements contaminate the area of each element. Room ambient light will contaminate the light emitted from the CRT. Well-controlled viewing conditions should yield a practical contrast ratio of 30:1 to 50:1.
  - **“DVI”**: Digital Visual Interface. The digital video connectivity standard that was developed by DDWG (Digital Display Work Group). This connection standard offers two different connectors: one with 24 pins that handles digital video signals only, and one with 29 pins that handles both digital and analog video.
  - **“EDID”**: Extended Display Identification Data – EDID is a data structure used to communicate video display information, including native resolution and vertical interval refresh rate requirements, to a source device. The source device will then output the optimal video format for the display based on the provided EDID data, ensuring proper video image quality. This communication takes place over the DDC – Display Data Channel.
  - **“Ethernet”**: A Local Area Network (LAN) standard officially known as IEEE 802.3. Ethernet and other LAN technologies are used for interconnecting computers, printers, workstations, terminals, servers, etc. within the same building or campus. Ethernet operates over twisted pair and over coaxial cable at speeds starting at 10Mbps. For LAN interconnectivity, Ethernet is physical link and data link protocol reflecting the two lowest layers of the OSI Reference Model.
  - **“Frame”**: In interlaced video, a frame is one complete picture. A video frame is made up of two fields, or two sets of interlaced lines. In a film, a frame is one still picture of a series that makes up a motion picture.
  - **“Gamma”**: The light output of a CRT is not linear with respect to the voltage input. The difference between what you should have and what is actually output is known as gamma.
  - **“HDMI” - High – Definition Multimedia Interface**: An interface used primarily in consumer electronics for the transmission of uncompressed high definition video, up to 8 channels of audio, and control signals, over a single cable. HDMI is the de facto standard for HDTV displays, Blu-ray Disc players, and other HDTV electronics. Introduced in 2003, the HDMI specification has gone through several revisions.
  - **“HDSDI”**: The high-definition version of SDI specified in SMPTE-292M. This signal standard transmits audio and video with 10 bit depth and 4:2:2 color quantization over a single coaxial cable with a data rate of 1.485 Gbit/second. Multiple video resolutions exists including progressive 1280x720 and interlaced 1920x1080 resolution. Up to 32 audio signals are carried in the ancillary data.
  - **“JPEG” (Joint photographic Expects Group)**: Commonly used method of lossy compression for photographic images using a discreet cosine transfer function. The degree of compression can be adjusted, allowing a selectable tradeoff between storage size and image quality. JPEG typically achieves 10:1 compression with little perceptible loss in image quality. Produces blocking artifacts.
  - **“MPEG”**: Motion Picture Expects Group. A standard committee under the auspices of the

International Standards Organization working on algorithm standards that allow digital compression, storage and transmission of moving image information such as motion video, CD-quality audio, and control data at CD-ROM bandwidth. The MPEG algorithm provides inter-frame compression of video images and can have an effective compression rate of 100:1 to 200:1.

- **“NTSC”**: The color video standard used in North America and some other parts of the world created by the National Television Standards Committee in the 1950s. A color signal must be compatible with black-and-white TV sets. NTSC utilizes an interlaced video signals, 525 lines of resolution with a refresh rate of 60 fields per second (60 Hz). Each frame is comprised of two fields of 262.5 lines each, running at an effective rate of 30 frames per second.
- **“Operator”**: Refers to the person who uses the system.
- **“PAL”**: Phase Alternate Line. A television standard in which the phase of the color carrier is alternated from line to line. It takes four full pictures (8 fields) for the color-to-horizontal phase relationship to return to the reference point. This alternation helps cancel out phase errors. For this reason, the hue control is not needed on a PAL TV set. PAL, in many transmission forms, is widely used in Western Europe, Australia, Africa, the Middle East, and Micronesia. PAL uses 625-line, 50-field (25 fps) composite color transmission system.
- **“PIP”**: Picture-in-Picture. A small picture within a larger picture created by scaling down one of the images to make it smaller. Each picture requires a separate video source such as a camera, VCR, or computer. Other forms of PIP displays include Picture-by-Picture (PBP) and Picture-with-Picture (PWP), which are commonly used with 16:9 aspect display devices. PBP and PWP image formats require a separate scaler for each video window.
- **“Polarity”**: The positive and negative orientation of a signal. Polarity usually refers to the direction or a level with respect to a reference (e.g. positive sync polarity means that sync occurs when the signal is going in the positive direction).
- **“RJ-45”**: Registered Jack-45. A connector similar to a telephone connector that holds up to eight wires, used for connecting Ethernet devices.
- **“RS-232”**: An Electronic Industries Association (EIA) serial digital interface standard specifying the characteristics of the communication path between two devices using either DB-9 or DB-25 connectors. This standard is used for relatively short-range communication and does not specify balanced control lines. RS-232 is a serial control standard with a set number of conductors, data rate, word length, and type of connector to be used. The standard specifies component connection standards with regard to the computer interface. It is also called RS-232-C, which is the third version of the RS-232 standard, and is functionally identical to the CCITT V.24 standard.
- **“Saturation”**: Chroma, chroma gain. The intensity of the color, or the extent to which a given color in any image is free from white. The less white in a color, the truer the color or the greater its saturation. On a display device, the color control adjusts the saturation. Not to be confused with the brightness, saturation is the amount of pigment in a color, and not the intensity. Low saturation is like adding white to the color. For example, a low-saturated red looks pink.
- **“Scaling”**: A conversion of a video or computer graphic signal from a starting resolution to a new resolution. Scaling from one resolution to another is typically done to optimize the

- signal for input to an image processor, transmission path or to improve its quality when presented on a particular display.
- **“SDI”**: Serial Digital Interface. The standard based on a 270 Mbps transfer rate. This is a 10-bit, scrambled, polarity independent interface with common scrambling for both component ITU-R 601 and composite digital video and four channels of (embedded) digital audio.
  - **“Seamless Switching”**: A feature found on many video switchers. This feature causes the switcher to wait until the vertical interval to switch. This avoid a glitch (temporary scrambling) which normally is seen when switching between sources.
  - **“SMPTE”**: Society of Motion Picture and Television Engineers. A global organization, based in the United States, that sets standards for baseband visual communications. This includes film as well as video and television standards.
  - **“S-Video”**: A composite video signal separated into the luma (“Y” is for luma, or black and white information; brightness) and the chroma (“C” is an abbreviation for chroma, or color information).
  - **“Sync”**: Synchronization. In video, sync is a means of controlling the timing of an event with respect to other events. This is accomplished with timing pulses to insure that each step in a process occurs at the correct time. For example, horizontal sync determines exactly when to begin each horizontal scan line. Vertical sync determines when the image is to be refreshed to start a new field or frame. There are many other types of sync in video system.(Also known as “sync signal” or “sync pulse.”)
  - **“TCP/IP”**: Transmission Control Protocol/Internet Protocol. The communication protocol of the Internet. Computers and devices with direct access to the Internet are provided with a copy of the TCP/IP program to allow them to send and receive information in an understandable form.
  - **“USB”**: Universal Serial Bus. USB was developed by seven PC and telecom industry leaders (Compaq, DEC, IBM, Intel, Microsoft, NEC, and Northern Telecom). The goal was easy plug-and-play expansion outside the box, requiring no additional circuit cards. Up to 127 external computer devices may be added through a USB hub, which may be conveniently located in a keyboard or monitor. USB devices can be attached or detached without removing computer power. The number of devices being designed for USB continues to grow, from keyboards, mice, and printers to scanners, digital cameras, and ZIP drives.
  - **“VESA”**: Video Electronics Standards Association. A nonprofit number organization dedicated to facilitating and promoting personal computer graphics through improved standards for the benefit of the end-user. [www.vesa.org](http://www.vesa.org)
  - **“VGA”**: Video Graphics Array. Introduced by IBM in 1987, VGA is an analog signal with TTL level separate horizontal and vertical sync. The video outputs to a 15-pin HD connector and has a horizontal scan frequency of 31.5 kHz and vertical frequency of 70 Hz (Mode 1, 2) and 60 Hz (Mode 3). The signal is non-interlaced in modes 1, 2, and 3 and interlaced when using the 8514/A card (35.5 kHz, 86 Hz) in mode 4. It has a pixel by line resolution of 640×480 with a color palette of 16 bits and 256,000 colors.
  - **“YCrCb”**: Used to describe the color space for interlaced component video.
  - **“YPbPr”**: Used to describe the color space for progressive-scan (non-interlaced) component video.

---

## 6.6 Revision History

The table below lists the changes to the Video Processor User Manual.

Format	Time	ECO#	Description	Principal
V1.0	2016-06-12	0000#	Release	Vira
V1.1	2016-08-11	0001#	Update and add the product codes.	Vira
V1.2	2016-11-03	0002#	Add "Questions and Troubleshooting".	Vira